

Financial Valuation of Supply Chain Contracts

MUSTAFA Ç. PINAR, ALPER ŞEN, AND A. GÖKAY ERÖN

We consider a single buyer—single supplier multiple period quantity flexibility contract in which the buyer has options to order additional quantities of goods in case of a higher than expected demand in addition to the committed purchases at the beginning of each period of the contract. We take the buyer's point of view and find the maximum value of the contract for the buyer by analyzing the financial and real markets simultaneously. We assume both markets evolve as discrete scenario trees. Under the assumption that the demand of the item is perfectly positively correlated with the price of a risky security traded in the financial market, we present a model to find the buyer's maximum acceptable price of the contract. Applying duality theory of linear programming, we obtain a martingale expression for the value of the contract. Finally, an experimental study is presented to illustrate the impacts of various parameters on the values of the contract and the option.

9.1 Introduction

In an effort to reduce mismatches between supply and demand, many companies have recently been looking into their relationships with their supply chain partners. These relationships are formally structured through supply contracts which specify the terms of a binding agreement between a seller and a buyer, whether the buyer is a manufacturer purchasing raw materials from a supplier, a wholesaler purchasing finished goods from a manufacturer or a retailer purchasing goods from a wholesaler. The terms in a supply contract include pricing and discounts, minimum quantities and flexibility terms, delivery terms, lead times, and quality and product return policies. Proper specification of these terms to align the incentives and coordinate the supply chain has become an important subject in operations management practice and literature.

Many supply contracts focus on the use of contractual flexibility in terms of purchased quantities in better handling the demand uncertainty at the end customer level. Various flexibility terms can be employed to transfer the risk to a party that can absorb it at a lower cost. For example, under a *backup agreement* for fashion goods, the buyer commits to a total quantity over a single selling season. The seller delivers a prespecified portion of the total quantity at the start of the season. The buyer may buy additional units up to the remaining commitment during the season and pays a penalty for any portion of the committed units that he did not purchase. Such contracts are used by major apparel and catalog companies and their suppliers (Eppen and Iyer 1997). In a similar contract with *return* or *buyback* terms, the buyer may return unsold items at a credit to the seller (Pasternack 1985). Return provisions are commonplace in distribution of many goods including books, newspapers, recorded music, and computer hardware and software (Padmanabhan and Png 1995). In *quantity–flexibility* contracts, the buyer first provides a forecast to the seller before season and is able to order within prespecified limits of this forecast during the season. These contracts are used heavily in high tech industry (Bassok et al. 1997, Tsay 1999). In *capacity reservation* contracts, the buyer reserves a portion of the seller's capacity at a reservation price, which he can later use by paying an execution price (Barnes-Schuster et al. 2002, Serel et al. 2001). Capacity reservation contracts are important as (1) other major contracts mentioned above can be shown to be their special cases (see Barnes-Schuster et al. 2002 and Cachon and Lariviere 2001) and (2) they mimic the (call) options in financial markets, which received enormous attention since the seminal article by Black and Scholes (1973). Note that in addition to contract terms discussed above, there are other provisions in supply contracts to entice the buyer to take more risk and order more. These include price protection in personal computers (Lee et al. 2000), markdown money in consumer goods (Tsay 2002), and revenue sharing terms in video rental industries (Cachon 2005). The now broad operations management literature on supply contracts generally studies the benefits of different contractual terms on buyer and/or seller, the factors that moderate these benefits and the ability of these terms to coordinate the supply chain under various settings and assumptions. Two excellent reviews of this literature are provided in Cachon (2003) and Tsay et al. (1998).

In this chapter, we develop a formal approach for valuation of flexible supply contracts under demand uncertainty. In particular, we consider the valuation of the capacity reservation or *option* contracts in which the buyer has the option (but not obligation) to purchase additional quantities up to the capacity reservation during the season, in addition to possible firm commitments (*forwards*) to be delivered before or during the season. Several researchers addressed the issue of valuation or pricing of these contracts in operations management literature. In Cheng et al. (2006), the authors model the price negotiation process as a Stackelberg game, where the seller is the leader and determines the option/exercise prices and the buyer is the follower and chooses an initial firm commitment and the number of option contracts to purchase in a single period setting. In Barnes-Schuster et al. (2002), the authors use a two-period model with correlated demand between periods and determine the seller's optimal pricing and production decisions. Here, the seller determines the wholesales prices for firm commitments in two periods as well as the optimal option/exercise prices. In Li et al. (2009), the authors assume that the buyer is privately informed about the market price and demand, and show that this asymmetry in information may lead to a different seller valuation of these contracts. In Ritcken and Tapiero (1986), the authors determine the conditions under which the options provide benefits over inventory building when the market demand and spot price are stochastic and correlated for a risk-averse decision maker with quadratic utility. In all four models, however, the analysis is carried out in the absence of financial markets. Ignoring the impact of financial markets is common not only in supply contracts literature, but also in other areas of operations management research. This is despite the extensive use of financial instruments by real sector companies when managing their operations. For example, according to a recent study, 60.3% of 7,319 nonfinancial firms worldwide use financial derivatives (Bartram et al. 2009).

The main contribution in this chapter is the formal integration of financial markets in valuation of flexible supply contracts under uncertain demand. This is important for three reasons: First, the financial markets may provide another means (in addition to the flexibility terms provided in the supply contract) to hedge against the inventory risk faced by individual players in the supply chain. Second, the true valuation (net of the value obtained by trading in financial markets) of flexibility terms can be obtained. Third, public (and perhaps advance) information regarding the financial markets can be used for better specification of contract terms and increasing the profitability under these terms due to possible correlation between financial and real market evolutions.

Several papers study the impact of financial markets on operational decisions. Gaur and Seshadri (2005) study the problem of hedging the inventory risk in a single period newsvendor model when the demand is correlated with the price of a financial asset. The authors show how to construct optimal hedging transactions and among other things, show that hedging increases the order quantity of a risk averse newsvendor. Burnetas and Ritchken (2005) study the role of option contracts when the retail price is a linear function of a stochastic market size factor and total quantity released to the market (purchased goods plus goods available through exercised options). It is assumed that there is a traded security

that spans the uncertainty in the demand curve and a riskless bond that leads to a complete market and valuations that are independent of risk preferences of the buyer and seller. The conditions under which the options benefit the seller and buyer are investigated. Ding et al. (2007) study the integrated operational and financial hedging decisions of a global firm selling in two markets with demand and exchange rate uncertainties. It is shown that the operational and financial hedging strategies are tightly interlinked and the lack of use of financial hedges can have significant effect on supply chain structural decisions such as the location and the number of production facilities to satisfy global demand. Caldentey and Haugh (2009) study the performance of a supply chain that consists of seller and buyer in a newsvendor setting. The buyer purchases a single product from the seller and resells it at the retail market at a stochastic retail price. It is assumed that the returns in a financial market and the retail price are dependent. It is also assumed that the buyer is budget constrained. Under a flexible contract, the seller offers a menu of wholesale contracts based on the particular evolution of the financial market until a certain time before the season and the buyer commits to an order quantity. Under a flexible contract with hedging, the buyer is able to continuously trade in the financial market before he places his order. It is shown that while the seller always prefers the flexible contract with hedging, the choice depends on the model parameters for the buyer. Finally, Chen and Parlar (2007) study the value of a put option for a risk averse vendor. The payoff of the put option in this model is contingent on the realized value of the demand.

In this paper, we use a stochastic programming approach for the financial valuation of flexible supply contracts. In this regard, we follow the approach in King (2002), who develops a stochastic programming formulation for pricing contingent claims (options) in the discrete time, discrete state case. King (2002) shows that the absence of arbitrage in the hedging problem is equivalent to the existence of a probability measure that makes the price process a martingale in the dual problem. He also shows that in complete markets the dual problem determines the unique valuation operator (equivalent risk neutral martingale measure). Delft and Vial (2004) use a similar stochastic programming approach in evaluation of supply contracts. Their model, however, does not include any financial instruments and thus does not capture the important impact of financial markets.

As in King (2002), we assume that financial and real markets evolve as discrete scenario trees. We further assume that there is a perfect correlation between the demand and the price of a risky asset traded in the financial market, which implies that the scenario trees of the markets coincide. This assumption is partially validated by Gaur and Seshadri (2005) who show that there is significant correlation between the year-to-year same-store sales growth in 60 large U.S. retailers and the same period returns on the S&P 500 index. In our model, the buyer borrows by short selling stocks in the financial market to acquire the contract and an investment portfolio. He closes the short position in later periods by transactions in financial markets and proceeds of operations in the real market. Thus, our approach allows us to find the maximum price that the buyer should accept to pay for the contract by studying the financial and real markets simultaneously.

The organization of the chapter is as follows: In Section 9.2, we review the stochastic process governing the security prices. Furthermore, we introduce financial markets and the basic concepts (arbitrage and martingales) of our analysis. In Section 9.3, the real market is introduced and the relation between the financial and real markets is described. The assumptions and notations are listed, and the model is described in detail. In Section 9.4, we apply duality theory of linear programming to obtain a martingale expression for the value of the contract. In Section 9.5, we conduct a numerical study to analyze the parameters affecting the valuation of the buyer, and give some managerial insights. We conclude in Section 9.6 with a short summary.

9.2 Review of Financial Markets, Arbitrage, and Martingales

A financial market is a mechanism that allows people to buy and sell financial securities. Throughout the chapter we assume as in King (2002) that all random quantities are supported on a finite probability space (Ω, \mathcal{F}, P) whose atoms ω are sequences of real valued vectors (security prices and payments) over the discrete time periods $t = 0, 1, \dots, T$. In addition, we assume that the market evolves as a discrete scenario tree. In the scenario tree, the partition of probability atoms $\omega \in \Omega$, which are generated by matching path histories up to time t corresponds one-to-one with nodes $n \in N_t$ at level t in the tree. The root node $n = 0$ corresponds to trivial partition $N_0 = \Omega$, and the leaf nodes $n \in N_T$ correspond one-to-one with the probability atoms $\omega \in \Omega$.

As shown in Figure 9.1, in the scenario tree, every node $n \in N_t$ for $t = 1, \dots, T$ has a unique parent node denoted by $a(n) \in N_{t-1}$, and every node $n \in N_t$, $t = 0, 1, \dots, T - 1$ has a nonempty set of child nodes denoted by $C(n) \subset N_{t+1}$. The tree evolution described Figure 9.1 is more general than a

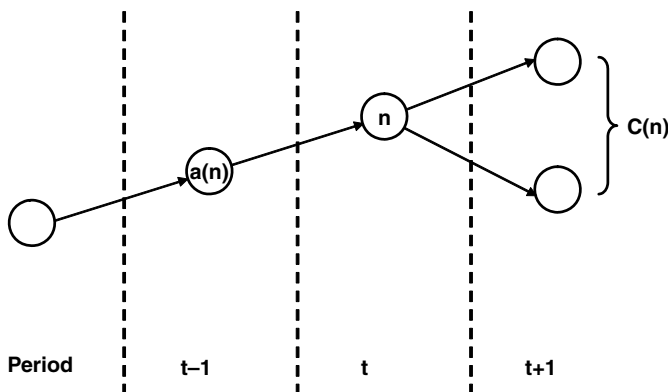

FIGURE 9.1 Financial Market Scenario Tree

recombinant binomial tree evolution usually used in introductory options pricing analysis. In a binomial tree with recombination (i.e., when a node can have more than one parent) and two assets (one riskless and one risky asset) the market is complete, and the portfolio strategies are naturally chosen to be path-independent. However, in incomplete markets it is known that path-independent strategies can be suboptimal. Therefore, to implement path-dependent strategies, the nonrecombinant tree evolution model (where each node has a unique parent) described in this chapter is more suitable. The examples given in the chapter are binomial but are nonrecombinant, hence suitable for incomplete markets. Therefore, the models used in the chapter are general as discussed in Edirisinghe et al. (1993).

The probability distribution P assigns positive weights p_n to each leaf node $n \in N_T$ in such a way that $\sum_{n \in N_T} p_n = 1$. Each intermediate level node in the tree receives a probability mass equal to the combined mass of the paths passing through it:

$$p_n = \sum_{u \in C(n)} p_u \quad \forall n \in N_t, \quad t = T - 1, \dots, 0$$

The ratios p_u/p_n , $u \in C(n)$, are the conditional probabilities that the child node u occurs given that the parent node $n = a(u)$ has occurred.

The function $X : \Omega \rightarrow \mathbb{R}$ is a real-valued random variable if $\{\omega : X(\omega) \leq r\} \in \mathcal{F} \forall r \in \mathbb{R}$. Let X be a real-valued random variable. X can be lifted to N_t if it can be assigned a value on each node of N_t that is consistent with its definition on Ω (King 2002). This kind of random variable is said to be measurable with respect to the information contained in the nodes of N_t . A stochastic process $\{X_t\}$ is a time indexed collection of random variables such that each X_t is measurable with respect to N_t . The expected value of X_t is uniquely defined by

$$E^P [X_t] := \sum_{n \in N_t} p_n X_n$$

The conditional expectation of X_{t+1} on N_t is a random variable taking values over the nodes $n \in N_t$:

$$E^P [X_{t+1} | N_t] := \sum_{u \in C(n)} \frac{p_u}{p_n} X_u$$

The market consists of $J + 1$ traded securities indexed by $j = 0, 1, \dots, J$ with prices at node n given by the vector $S_n = (S_n^0, \dots, S_n^J)$. We suppose one of the securities, say security 0, always has strictly positive values at each node of the scenario tree. This security that corresponds to the risk free asset (bond) in the classical financial valuation framework is chosen to be *numéraire*. Introducing the discount factors $\beta_n = 1/S_n^0$, we define the discounted security prices relative to the numéraire and denote it by $Z_n = (Z_n^0, \dots, Z_n^J)$ where $Z_n^j = \beta_n S_n^j$ for $j = 0, 1, \dots, J$. Note that, $Z_n^0 = 1$ in any state n .

The amount of security j held by the investor in state $n \in N_t$ is denoted by θ_n^j . The value of the portfolio discounted with respect to the numéraire in state n is

$$Z_n \cdot \theta_n := \sum_{j=0}^J Z_n^j \theta_n^j$$

An *arbitrage* is a sequence of portfolio holdings that begins with a zero initial value, makes self-financing portfolio transactions and attains a non-negative value in each future state, while in at least one terminal state it attains a strictly positive value with positive probability.

The condition of self-financing portfolio transactions in the following equation states that the funds available for investment at state n are restricted to the funds generated by the price changes in the portfolio held at state $a(n)$.

$$Z_n \cdot \theta_n = Z_n \cdot \theta_{a(n)} \quad n > 0$$

The following optimization problem is used to find an arbitrage:

$$\begin{aligned} \max \quad & \sum_{n \in N_T} p_n Z_n \cdot \theta_n \\ \text{s.t.} \quad & \\ & Z_0 \cdot \theta_0 = 0 \\ & Z_n \cdot [\theta_n - \theta_{a(n)}] = 0, \quad \forall n \in N_t, t \geq 1 \\ & Z_n \cdot \theta_n \geq 0, \quad \forall n \in N_T \end{aligned}$$

The solution that yields a positive optimal value can be turned into an arbitrage as shown by Harrison and Pliska (1981). On the other hand if no arbitrage is possible, the price process is called an arbitrage-free market price process.

Martingale properties needed for our study are formalized in the following definition.

Definition 9.1 *If there exists a probability measure $Q = \{q_n\}_{n \in N_t}$ such that $Z_t = E^Q [Z_{t+1} | N_t]$, for all $t \leq T - 1$, then the vector process $\{Z_t\}$ is called a vector-valued martingale under Q , and Q is called a martingale probability measure (MPM) for the process.*

We further need the following definition.

Definition 9.2 *A discrete probability measure $Q = \{q_n\}_{n \in N_t}$ is said to be equivalent to a discrete probability measure $P = \{p_n\}_{n \in N_t}$ if $q_n > 0$ exactly when $p_n > 0$.*

The key link between arbitrage and martingales is the following theorem (c.f. Theorem 9.1 of King (2002)).

THEOREM 9.1 *The discrete state stochastic vector process $\{Z_t\}$ is an arbitrage-free market price process if and only if there is at least one probability measure Q equivalent to P under which $\{Z_t\}$ is a martingale.*

9.3 A Model for Financial Valuation of Supply Chain Contracts

We consider a general single buyer–single supplier contract where the buyer is an intermediary between the market and the supplier. He buys the finished products from the supplier and sells them to customers at the end market at a fixed market price that is exogenously specified. The buyer and the supplier sign a multiple period quantity flexibility contract, in which the buyer has options to place further orders in case of a higher than expected demand in addition to the committed purchases at the beginning of each period of the contract.

We assume that the demand of the customers for the finished products evolves as a discrete scenario tree. The nodes of the scenario tree represent the state of the discrete state stochastic process at a given period. The arcs correspond to the probabilistic transitions from one node at a given period to another node at the next period. As represented in Figure 9.2, there exists exactly one arc leading to a node, while there may be many arcs emanating from a node. As in the financial market scenario tree we denote the nodes obtained by the arcs emanating from node n , $n \in N_t$ for $t = 0, \dots, T - 1$ by $C(n) \subset N_{t+1}$, and the unique node that gives rise to node n , $n \in N_t$ for $t = 1, \dots, T$ by $a(n) \in N_{t-1}$.

Now, consider a periodic review inventory problem with horizon T . The decisions made by the buyer at the beginning of the horizon are as follows. The buyer orders Q_t units to be delivered in period t for $t = 1, \dots, T$ at a unit purchase price of p_t . We refer to Q_t as firm orders. In addition, the buyer purchases options from the supplier, which give him an opportunity to purchase additional

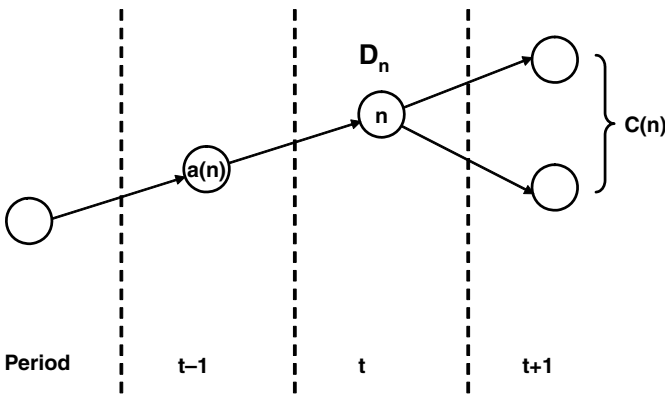

FIGURE 9.2 Demand Market Scenario Tree

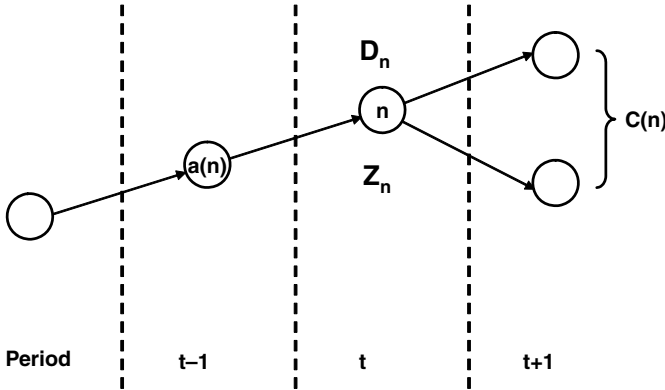

FIGURE 9.3 Financial and Demand Market Scenario Tree

units later by paying an exercise price. We assume that one option gives the buyer a right to purchase one additional unit of product, and this additional unit is delivered at the beginning of the next period. We further assume that the number of options exercised by the buyer at each node n , $n \in N_t$ for $t = 1, \dots, T - 1$ is denoted by m_n and is bounded above by a constant M . In each state n , $n \in N_t$ for $t = 1, \dots, T - 1$, after observing the actual demand of node n , the buyer decides whether to exercise options or not. Exercise price in period t is e_t .

In each period t for $t = 1, \dots, T - 1$, excess demand is assumed to be backlogged to the next period at a unit shortage cost s_t . However, at the end of the horizon, shortage is not allowed. In addition, in each period t , $t = 1, \dots, T$, excess inventory is carried to the next period at a unit holding cost of h_t .

We assume that demand forecast for the item is perfectly correlated with the price of a risky security traded in the financial market implying that the scenario tree of the financial market and the demand market coincide as shown in Figure 9.3.

Before moving on to the mathematical formulation of the model, we summarize the notation and assumptions relevant to the model.

9.3.1 NOTATION

Decision Variables

- V^M : Contract value with M options
- Q_t : Firm order to be delivered in period t
- θ_n : The vector amount of securities held at node n
- m_n : Number of options exercised at node n
- I_n^+ : Positive inventory at the end of node n
- I_n^- : Negative inventory at the end of node n
- I_n : Net inventory at the end of node n

Parameters

- M : Maximum number of options that can be exercised at node n
 r_t : Sales price of finished product at the end market in period t
 p_t : Purchase price of unit firm order Q_t in period t
 h_t : Unit holding cost for finished products in period t
 s_t : Unit stock-out cost for finished products in period t
 Z_n : The vector of security prices at node n
 D_n : Demand at node n
 e_t : Unit price for an option exercised in period t

9.3.2 ASSUMPTIONS

1. The demand forecast for the item is perfectly correlated with the price of an underlying security traded in the financial markets.
2. In the financial market, the price process $\{Z_t\}$ is an arbitrage-free market price process. This is equivalent to the existence of a martingale probability measure Q for the price process $\{Z_t\}$.
3. At each state n , $n \in N_t$ for $t = 1, \dots, T - 1$, the buyer is allowed to exercise at most M options and the options exercised are delivered at the beginning of period $t + 1$.
4. In the real market, in period t for $t = 1, \dots, T - 1$ excess demand is backlogged and excess inventory is carried to the next period. However, at the end of the horizon, shortage is not allowed.
5. The backorders are met at the present price.
6. To avoid trivial cases, it is assumed that the sales price r_t is greater than the purchase price p_t and the stock-out cost s_t is greater than the holding cost h_t in period t for $t = 1, \dots, T$.
7. Initial inventory is assumed to be zero, and we have no salvage value at the end of the horizon.
8. The buyer is assumed to be risk-neutral.
9. The firm orders (Q_t) and the number of options to be exercised (m_n) are assumed to take real values.

9.3.3 THE MODEL

The aim of the model is to find the maximum value (V^M) that the buyer is willing to pay for the contract. Hence, the objective is to maximize the value of the contract. Since the portfolio of the buyer is empty before borrowing money, and the money borrowed (by shorting stocks or bonds) at the beginning of the horizon is used to acquire the contract and acquire the stock or bond to later trade in the financial market, the portfolio of stocks, bonds and the value of the

contract must add up to *zero*, which constitutes $Z_0 \cdot \theta_0 + V^M = 0$ (constraint [9.1] below).

The portfolio value at each node n , $Z_n \cdot \theta_n$, is composed of the portfolio value of parent node $a(n)$, $Z_n \cdot \theta_{a(n)}$, and the cash flow generated in the real market at node n denoted by F_n . Therefore, the following equation describes the self-financing nature of portfolio transactions:

$$Z_n \cdot \theta_n = Z_n \cdot \theta_{a(n)} + F_n$$

or,

$$Z_n \cdot (\theta_n - \theta_{a(n)}) = F_n$$

Denote $\theta_n - \theta_{a(n)}$ by $\Delta\theta_n$ then we have

$$Z_n \cdot \Delta\theta_n = F_n$$

With above specifications, our model, referred to as (P1), can be formulated as follows.

$$\max V^M$$

s.t.

$$Z_0 \cdot \theta_0 + V^M = 0 \quad (9.1)$$

$$\begin{aligned} Z_n \cdot \Delta\theta_n + r_1 I_n^- + p_1 Q_1 + e_1 m_n \\ + h_1 I_n^+ + s_1 I_n^- = r_1 D_n \quad \forall n \in N_1 \end{aligned} \quad (9.2)$$

$$\begin{aligned} Z_n \cdot \Delta\theta_n + r_t (I_n^- - I_{a(n)}^-) + p_t Q_t \\ + e_t m_n + h_t I_n^+ + s_t I_n^- = r_t D_n \quad \forall n \in N_t, t = 2, \dots, T-1 \end{aligned} \quad (9.3)$$

$$\begin{aligned} Z_n \cdot \Delta\theta_n - r_T I_{a(n)}^- + p_T Q_T \\ + h_T I_n = r_T D_n \quad \forall n \in N_T \end{aligned} \quad (9.4)$$

$$Z_n \cdot \theta_n \geq 0 \quad \forall n \in N_T \quad (9.5)$$

$$Q_1 - I_n = D_n \quad \forall n \in N_1 \quad (9.6)$$

$$I_{a(n)} + Q_t + m_{a(n)} - I_n = D_n \quad \forall n \in N_t, t = 2, \dots, T \quad (9.7)$$

$$I_n - I_n^+ + I_n^- = 0 \quad \forall n \in N_t, t = 1, \dots, T-1 \quad (9.8)$$

$$I_n \geq 0 \quad \forall n \in N_T \quad (9.9)$$

$$m_n \leq M \quad \forall n \in N_t, t = 1, \dots, T-1 \quad (9.10)$$

$$m_n \geq 0 \quad \forall n \in N_t, t = 1, \dots, T-1 \quad (9.11)$$

$$Q_t \geq 0 \quad t = 1, \dots, T \quad (9.12)$$

$$I_n^+ \geq 0 \quad \forall n \in N_t, t = 1, \dots, T \quad (9.13)$$

$$I_n^- \geq 0 \quad \forall n \in N_t, t = 1, \dots, T-1 \quad (9.14)$$

Constraint (9.2) implies that F_n for $n \in N_1$ is the revenue in period 1, which is composed of the amount of the product sold at a unit sales price of r_1 , minus

the expenditure in period 1, which is the firm order at a unit purchase price of p_1 , the amount of options exercised to be used in the second period at a unit exercise price of e_1 , the positive inventory at a unit cost of h_1 and the backorder amount at a unit cost of s_1 :

$$F_n = r_1 (D_n - I_n^-) - (p_1 Q_1 + e_1 m_n + h_1 I_n^+ + s_1 I_n^-) \quad \forall n \in N_1$$

Constraint (9.3) states that F_n for $n \in N_t$, $t = 2, \dots, T - 1$ is the revenue in period t , $t = 2, \dots, T - 1$, that is, the demand at node n plus the backorder amount at node $a(n)$ minus the shortage at node n at a unit sales price of r_t , minus the expenditure in period t , $t = 2, \dots, T - 1$, that is, the firm order, the number of options exercised in period t to be used in period $t + 1$, the positive inventory and the backorder amount at unit prices of p_t , e_t , h_t and s_t :

$$F_n = r_t (D_n - I_n^- + I_{a(n)}^-) - (p_t Q_t + e_t m_n + h_t I_n^+ + s_t I_n^-) \quad \forall n \in N_t, t = 2, \dots, T - 1$$

Constraint (9.4) ensures that F_n for $n \in N_T$ is the revenue in the last period, which is the demand at node n plus the backorder amount coming from parent node $a(n)$ at a unit sales price of r_T since shortage is not allowed in the last period, minus the expenditure, which is the firm order at a unit purchase price p_T plus the positive inventory held at node n at a unit cost of h_T since in the last period options cannot be exercised and shortage is not allowed:

$$F_n = r_T (D_n + I_{a(n)}^-) - (p_T Q_T + h_T I_n) \quad \forall n \in N_T$$

Constraint (9.5) guarantees that the value of the portfolio in the terminal states are non-negative. This is needed to assure that the buyer has repaid fully the initial debt from short positions.

Constraints (9.6), (9.7), (9.8), and (9.9) are the inventory balance constraints. Constraint (9.6) implies that in the first period the net inventory at each state n , $n \in N_1$ is equal to the firm order for period 1 minus the demand at that node since there is no backorder to cover or positive inventory carried from the previous period.

Constraint (9.7) states that in period t , $t = 2, \dots, T$ the net inventory at each state n , $n \in N_t$ is equal to the sum of the net inventory of the parent node $a(n)$, the firm order of period t and the number of options exercised in period $t - 1$ to be delivered in period t minus the demand at state n . The reason is that except the first period, the buyer is allowed to carry positive or negative inventory from the previous periods. Furthermore, the buyer has an opportunity to use options bringing as many additional units as the number of options exercised.

Constraint (9.8) implies that in period t , $t = 1, \dots, T - 1$, the net inventory at any node is equal to positive inventory minus the negative inventory at that node. However, the net inventory in the last period is simply the positive inventory, since shortage is not allowed at the end of the horizon. This is guaranteed in constraint (9.9).

Constraint (9.10) shows the flexibility of the buyer. It states that at any node that the buyer is allowed to exercise options which is all the periods except the last period, he is permitted to exercise at most M options.

The resulting optimization model is a linear programming problem, which can be efficiently solved by off-the-shelf optimization software.

9.4 Dual Formulation

This section analyzes the problem discussed in Section 9.3 through an equivalent dual formulation. We first examine the financial constraints in the dual corresponding to the decision variables θ_n for $n \in N_t$, $t = 0, \dots, T$. The first step in calculating the dual is to assign dual variables to each constraint in the model. We assign q_n as dual variables for all the nodes of the financial constraints (9.1–9.4), and w_n for the non-negativity constraint of the portfolio in the terminal nodes, that is, constraint (9.5), $\forall n \in N_T$.

Firstly, the dual constraint corresponding to the decision variable V^M , that is the value of the contract, is:

$$q_0 = 1 \quad (9.15)$$

Next, the dual constraint corresponding to θ_n , $n \in N_t$ for $t = 0, \dots, T - 1$ is the martingale condition:

$$q_n Z_n = \sum_{u \in C(n)} q_u Z_u \quad n \in N_t, t = 0, \dots, T - 1 \quad (9.16)$$

The dual constraint corresponding to the decision variables θ_n for $n \in N_T$ is:

$$(q_n + w_n) Z_n = 0 \quad n \in N_T$$

Since the first component $Z_n^0 = 1$ for all states n we have:

$$q_n + w_n = 0 \quad n \in N_T$$

In addition, by the non-negativity of the portfolio in the terminal positions:

$$w_n \leq 0 \quad n \in N_T$$

Finally, combining the above two constraints, one has the following constraint in the dual:

$$q_n \geq 0 \quad n \in N_T \quad (9.17)$$

We assign dual multipliers y_n to the inventory balance constraints (9.6) and (9.7), $\forall n \in N_t$, $t = 1, \dots, T$, k_n to constraint (9.8), $\forall n \in N_t$, $t = 1, \dots, T - 1$, and f_n to the flexibility constraint (9.10), $\forall n \in N_t$, $t = 1, \dots, T - 1$. The dual

constraint corresponding to the firm orders Q_t is:

$$\sum_{n \in N_t} p_t q_n + y_n \geq 0 \quad t = 1, \dots, T \quad (9.18)$$

The constraint in the dual arising from the number of options exercised (i.e. m_n), $n \in N_t, t = 1, \dots, T - 1$ is:

$$e_t q_n + f_n + \sum_{u \in C(n)} y_u \geq 0 \quad n \in N_t, t = 1, \dots, T - 1 \quad (9.19)$$

The dual constraint corresponding to the net inventory at state n , $n \in N_t, t = 1, \dots, T - 1$ is:

$$-y_n + \sum_{u \in C(n)} y_u + k_n = 0 \quad n \in N_t, t = 1, \dots, T - 1$$

Reformulating the above constraint, one obtains:

$$k_n = y_n - \sum_{u \in C(n)} y_u \quad n \in N_t, t = 1, \dots, T - 1$$

The constraint in the dual arising from the positive inventory at state n , $n \in N_t, t = 1, \dots, T - 1$ is:

$$h_t q_n - k_n \geq 0 \quad n \in N_t, t = 1, \dots, T - 1$$

and The dual constraint associated with the negative inventory at state n , $n \in N_t, t = 1, \dots, T - 1$ is:

$$(r_t + s_t) q_n - r_{t+1} \sum_{u \in C(n)} q_u + k_n \geq 0 \quad n \in N_t, t = 1, \dots, T - 1$$

Replacing k_n by $y_n - \sum_{u \in C(n)} y_u$ one has the following constraints in the dual corresponding to, respectively, positive and negative inventory at state n , $n \in N_t, t = 1, \dots, T - 1$:

$$h_t q_n - y_n + \sum_{u \in C(n)} y_u \geq 0 \quad n \in N_t, t = 1, \dots, T - 1 \quad (9.20)$$

$$(r_t + s_t) q_n - r_{t+1} \sum_{u \in C(n)} q_u + y_n - \sum_{u \in C(n)} y_u \geq 0 \quad n \in N_t, t = 1, \dots, T - 1 \quad (9.21)$$

Finally, the dual constraint corresponding to the net inventory at the terminal positions (which is also the positive inventory since shortages are not allowed in the last period) is:

$$h_T q_n - y_n \geq 0 \quad n \in N_T \quad (9.22)$$

Therefore, the dual program, which we refer to as (D1), is as follows:

$$\begin{aligned} \min \quad & \sum_{t=1}^T \sum_{n \in N_t} D_n (r_t q_n + y_n) + M \sum_{t=1}^{T-1} \sum_{n \in N_t} f_n \\ \text{s.t.} \quad & \\ (15 - 22) \quad & f_n \geq 0 \quad n \in N_t, t = 1, \dots, T - 1 \end{aligned}$$

The basic theorem of linear programming states that problem (P1) has an optimal solution if and only if the dual (D1) does too, and both optimal values are equal. Furthermore, it follows again from the theory of linear programming that problem (P1) has an optimal solution if and only if it is feasible and bounded. Moreover, (P1) is bounded if and only if there exists at least one probability measure Q under which the price process $\{Z_t\}$ is martingale, and there exists y_n and f_n satisfying (9.18–9.22).

Now, assume the financial market is arbitrage-free, and let \mathcal{M} denote the set of probability measures Q making the stock price process a martingale. Then, we can summarize our findings above in the result below.

THEOREM 9.2 *The maximum value that the buyer will accept to pay for the contract is:*

$$\min_{Q \in \mathcal{M}} \left\{ \sum_{t=1}^T \sum_{n \in N_t} D_n (r_t q_n + y_n^*) + M \sum_{t=1}^{T-1} \sum_{n \in N_t} f_n^* \right\}$$

where y^* and f^* are the optimal solution of the following linear program that we refer to as (D2):

$$\begin{aligned} \min \quad & \sum_{t=1}^T \sum_{n \in N_t} D_n y_n + M \sum_{t=1}^{T-1} \sum_{n \in N_t} f_n \\ \text{s.t.} \quad & \\ & \sum_{n \in N_t} y_n \geq - \sum_{n \in N_t} p_t q_n \quad t = 1, \dots, T \end{aligned} \quad (9.23)$$

$$f_n + \sum_{u \in C(n)} y_u \geq -e_t q_n \quad n \in N_t, t = 1, \dots, T - 1 \quad (9.24)$$

$$y_n - \sum_{u \in C(n)} y_u \leq h_t q_n \quad n \in N_t, t = 1, \dots, T - 1 \quad (9.25)$$

$$\begin{aligned} & y_n - \sum_{u \in C(n)} y_u \geq r_{t+1} \\ & \sum_{u \in C(n)} q_u - (r_t + s_t) q_n \quad n \in N_t, t = 1, \dots, T - 1 \end{aligned} \quad (9.26)$$

$$y_n \leq h_T q_n \quad n \in N_T \quad (9.27)$$

$$f_n \geq 0 \quad n \in N_t, t = 1, \dots, T - 1. \quad (9.28)$$

We first note that when the financial market is complete and arbitrage-free, the set \mathcal{M} is a singleton in which case, it suffices to solve (D2) in Theorem 9.2 to solve the dual problem, given the unique martingale measure, Q^* say.

From Theorem 9.2, we can also make the following observation.

OBSERVATION 9.1 *If $f_n^* = 0$, an increase in the value of M does not have any effect on the value of the contract since*

$$M \sum_{t=1}^{T-1} \sum_{n \in N_t} f_n^* = 0$$

This actually means that the buyer is flexible enough to exercise as many options as he wants even before an increase in the value of M , that is, the primal constraints corresponding to f_n for $n \in N_t$, $t = 1, \dots, T - 1$ are all nonbinding.

9.5 Experimental Study

In this section, we explore the parameters that moderate the benefits that the buyer receives from options in supply contracts. The value of $M = \mu$ options (often referred to as *option value* in the rest of the chapter) available in a supply contract can be determined by subtracting the value of the contract when $M = 0$ from the value of the contract when $M = \mu$. This is necessary, as the model we study has an operating profit even when the use of option is not allowed. The value of a contract is found by solving the linear program (P1) in Section 9.3.3. For simplicity, we first conduct all the analysis in a two-period model and consider the binomial tree shown in Figure 9.4. A three-period model is considered when

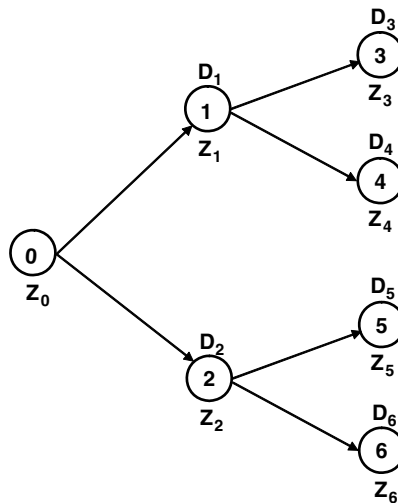

FIGURE 9.4 Two-Period Binomial Tree with $p = 1/2$

need arises. We assume that there is only one risky security and one riskless asset in the financial market.

From Figure 9.4, we have

$$\begin{aligned}
 N_0 &= \{0\}, & N_1 &= \{1, 2\}, & N_2 &= \{3, 4, 5, 6\} \\
 a(1) &= 0, & a(2) &= 0 \\
 a(3) &= 1, & a(4) &= 1 \\
 a(5) &= 2, & a(6) &= 2 \\
 Z_n &= (Z_n^0, Z_n^1) & n &= 0, \dots, 6
 \end{aligned}$$

Note that Z_n^0 denotes the price of the riskless asset, and Z_n^1 denotes the price of the risky security.

In order to observe the effect of volatility of stock prices, the stock prices are chosen in such a way that the average price remains constant in all periods:

$$Z_0^1 = (Z_1^1 + Z_2^1) / 2 = (Z_3^1 + Z_4^1 + Z_5^1 + Z_6^1) / 4$$

Demands at each node are also set so that the average values remains constant in all periods to observe the impact of demand volatility:

$$(D_1 + D_2) / 2 = (D_3 + D_4 + D_5 + D_6) / 4$$

Under the above specifications, the values of the parameters and the corresponding decision variables in a base case are represented in Table 9.1. The value of the contract (V^M) is 146.7857 and the value of the option is $V^M - V^0 = 482.30 - 416.68 = 65.62$. Notice that the buyer takes a short position in the stock, the proceeds of which are used to finance the contract and the purchase of bonds.

Throughout the analysis, graphs are plotted by taking the sample size of the parameters large enough to recognize a general pattern. Solid lines represent the value of the contract, and the dashed lines represent the value of the option.

TABLE 9.1 Parameters and Decision Variables in Base Case

Parameters	Decision Variables	n	Z_n^0	Z_n^1	D_n	θ_n^0	θ_n^1	F_n	m_n
	$Q_1 = 45$	0	10	15		45.902	-62.754		
$r_t = 20$	$Q_2 = 20$	1	12	20	45	-13.064	-26.875	10.0	35
$p_t = 12$	$V^0 = 416.68$	2	12	10	25	19.767	-38.393	-70.0	0
$b_t = 1.5$	$V^M = 482.30$	3	14.4	25	55			860.0	
$s_t = 2.5$	$I_2^+ = 20$	4	14.4	5	30			322.5	
$M = 100$	$I_4 = 25$	5	14.4	22	40			560.0	
$e = 10$	$I_6 = 25$	6	14.4	8	15			22.5	

9.5.1 CASE 1: EFFECT OF NUMBER OF OPTIONS

The buyer is allowed to purchase options from the supplier at the beginning of the horizon to later exercise and obtain additional units. The buyer, however, is not fully flexible to adjust order quantities to the observed demands. At each state n , $n \in N_t$, $t = 1, \dots, T - 1$, he is allowed to exercise at most M options. Thus, the value of M plays an important role in determining the value of the contract and the option. As shown in Figure 9.5, the values of the contract and the option are unchanged as long as the buyer is flexible enough to exercise the amount used in the base case. However, decreasing the value of M to an amount lower than the amount of options exercised in the base case decreases the values of the contract and the option.

9.5.2 CASE 2: EFFECT OF EXERCISE PRICE

The buyer can use options to obtain additional units only after paying an exercise price. Thus, the price that the buyer pays to exercise options affects the values of the option and the contract. Obviously, an increase (decrease) in exercise price leads to a decrease (increase) in the value of the contract and option value. This is shown in Figure 9.6 for our problem.

9.5.3 CASE 3: EFFECT OF PURCHASE PRICE

At the beginning of the horizon, the buyer orders Q_t units at a unit purchase price of p_t to be delivered in period t , $t = 1, \dots, T$. Hence, the value of the purchase price has an effect on the value of the contract and the option. Table 9.2 shows the impact of purchase price in periods 1 and 2 on stock and option values. As expected, the value of the contract is nonincreasing in purchase prices, while the option value is nondecreasing. When the purchase price in period 1 (p_1) is too low at 6, the buyer places only firm orders in period 1, and does not exercise any options. This leads to zero option value. When p_1 is increased to 8, the buyer reduces the firm orders, and exercise options in the high demand

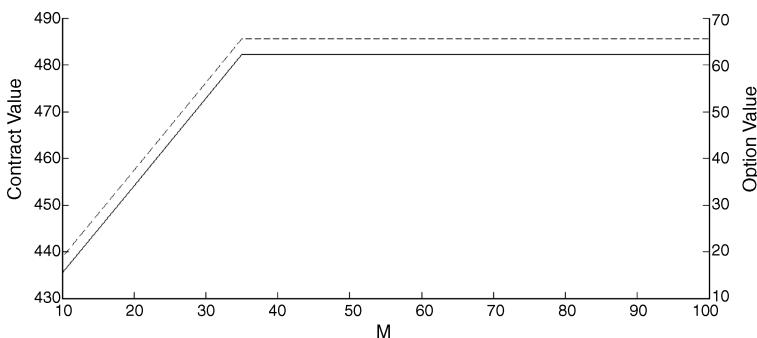

FIGURE 9.5 Contract and Option Values vs Number of Options (M)

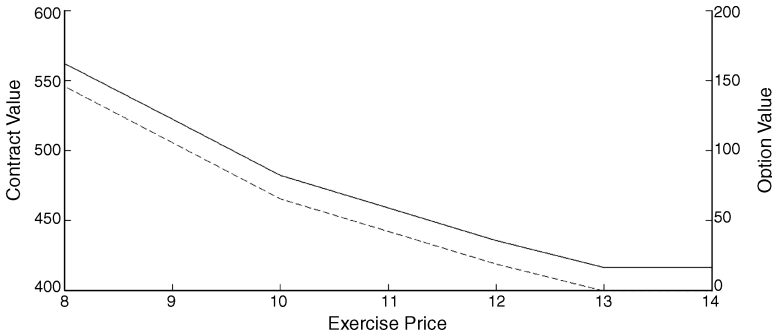

FIGURE 9.6 Contract and Option Values vs Exercise Price

scenario leading to a positive option value. At $p_1 = 10$, the buyer places a firm order of only 45 units in period 1 and uses options in period 2, regardless of the demand realization. Further increases in p_1 has no impact on option value since it does not impact the way the buyer uses options for period 2. When the purchase price in period 2 (p_2) is too low at 9, the buyer places only firm orders for periods 1 and 2 leading to again zero option value. As p_2 increases to 10, the buyer uses a mixture of firm orders and options in the high demand scenario, increasing the value of the options. When p_2 increases to 12, the buyer uses only options for period 2, which leads to a further increase in the value of the options.

9.5.4 CASE 4: EFFECT OF DEMAND VOLATILITY

More volatile demand leads to more mismatches between the supply and demand for the buyer. Since the options are used to correct mismatches of period 1 and

TABLE 9.2 Impact of Purchase Price with $M = 100$

p_1	p_2	Q_1	Q_2	m_1	m_2	V^0	V^M	$V^M - V^0$
6	12	100	0	0	0	756.26	756.26	0.00
8	12	65	0	35	0	640.63	589.59	51.04
10	12	45	0	55	20	491.68	557.30	65.62
12	12	45	20	35	0	416.68	482.30	65.62
14	12	45	20	35	0	341.68	407.30	65.62
16	12	0	65	35	0	297.38	363.00	65.62
12	9	25	75	0	0	533.48	533.48	0.00
12	10	45	20	35	0	493.07	510.08	17.01
12	11	45	20	35	0	454.87	496.19	41.32
12	12	45	20	35	0	416.68	482.30	65.62
12	13	45	0	55	20	378.48	482.30	103.82
12	14	45	0	55	20	340.29	482.30	142.01

TABLE 9.3 Impact of Demand Volatility with $M = 100$

D_1	D_2	D_3	D_4	D_5	D_6	Q_1	Q_2	m_1	m_2	V^0	V^M	$V^M - V^0$
40	30	55	30	40	15	40	0	55	30	421.26	468.13	46.87
45	25	55	30	40	15	45	20	35	0	416.68	482.30	65.62
50	20	55	30	40	15	50	10	45	0	412.07	496.47	84.40
45	25	50	35	40	15	45	0	50	20	409.80	466.05	56.25
45	25	55	30	40	15	45	20	35	0	416.68	482.30	65.62
45	25	60	25	40	15	45	20	40	0	423.55	498.55	75.00

to minimize the possible mismatch of period 2 by adjusting orders in accordance with observed demands, they are more valuable when the demand is more volatile. Table 9.3 shows the impact of demand volatility on contract and option values. The first half is regarding the volatility in period 1 and the second half is regarding the volatility in period 2. Both parts show that the options become more valuable as the volatility increases.

9.5.5 CASE 5: VOLATILITY OF STOCK PRICES

In order to analyze the impact of stock prices on contract and option values, we vary the volatility of the stock prices while keeping the mean of the stock prices constant throughout the horizon, that is:

$$Z_0^1 = (Z_1^1 + Z_2^1) / 2 = (Z_3^1 + Z_4^1 + Z_5^1 + Z_6^1) / 4$$

The value of the option corresponding to different values of stock prices are summarized in Table 9.4. We assume that other parameters take their base case values.

The first row of Table 9.4 (base case) shows that assuming the stock price pattern above, the buyer makes 62.754 short sales of stocks at the beginning of the horizon. The portfolio of stocks in node 1 and node 2, respectively, are -26.875 and -38.393 . This implies that the buyer has paid back part of the debt and has 26.875 and 38.393 remaining stocks to pay in node 1 and node 2, respectively. The value of the option is 65.62.

TABLE 9.4 Impact of Stock Volatility with $M = 100$

Z_0^1	Z_1^1	Z_2^1	Z_3^1	Z_4^1	Z_5^1	Z_6^1	θ_0	θ_1	θ_2	V^0	V^M	$V^M - V^0$
15	20	10	25	5	22	8	-62.754	-26.875	-38.393	416.68	482.30	65.62
15	19	11	25	5	22	8	-70.285	-26.875	-38.393	464.91	505.93	41.02
15	20	10	28	2	24	6	-55.970	-20.673	-29.861	389.22	454.84	65.62
15	21	9	28	2	24	6	-50.853	-20.673	-29.861	356.19	438.22	82.03
15	19	11	28	2	24	6	-63.646	-20.673	-29.861	436.84	477.86	41.02

First, we keep the stock prices in period 2 constant and analyze the effect of stock prices in period 1. We first observe that as the volatility of the stock prices in period 1 decreases, the value of the option also decreases, since the demand is perfectly correlated with the price of a risky security and it is period 1 in which the options are exercised.

Next, we investigate the case where the stock prices in period 1 are unchanged. The stock prices in period 2 do not have any impact on the value of the option. This is due to the fact that in period 2 (the terminal position), the buyer cannot exercise any options. However, the stock prices in period 2 impact the portfolio of stock in period 1, as the buyer needs to cover all his short sales and forms his portfolio in period 1 by considering the stock prices in the next period. This result is stated in the following observation.

OBSERVATION 9.2 *The stock prices in period 2 do not impact the value of the option, whereas they impact the portfolio of stock in period 1.*

9.5.6 CASE 6: EFFECT OF INTEREST RATE ON THE RISKLESS ASSET

The value of the option corresponding to different interest rates are summarized in Table 9.5. The values of the other parameters are taken as in the base case. The first row of Table 9.5 (base case) shows that if the interest rate on the riskless asset is 20%, the value of the option is 65.62. The buyer places 45 and 20 units firm orders for period 1 and 2 respectively. In node 1 the buyer exercises 35 options. As the interest rate on the riskless asset decreases, the buyer can make short sales of bonds in larger quantities and exercise more options with the cash borrowed to meet the demand in case of higher than expected demand. This leads to use of less firm orders and more options, and thus option value increases.

Thus far, all the cases were analyzed in a two-period setting. Since the analysis of the remaining parameters requires a higher dimensional model, we now extend our model to three periods, and consider the binomial tree shown in Figure 9.7.

From Figure 9.7, we have,

$$\begin{aligned} N_0 &= \{0\}, & N_1 &= \{1, 2\}, & N_2 &= \{3, 4, 5, 6\} \\ N_3 &= \{7, 8, 9, 10, 11, 12, 13, 14\} \\ a(1) &= a(2) = 0 \end{aligned}$$

TABLE 9.5 Impact of Interest Rate with $M = 100$

Interest rate(%)	Q_1	Q_2	m_1	m_2	V^0	V^M	$V^M - V^0$
20	45	20	35		416.68	482.30	65.62
10	45		55	20	286.66	458.66	172.00
0	25		75	40	111.20	452.45	341.25
25	45	20	35		469.22	497.22	28.00

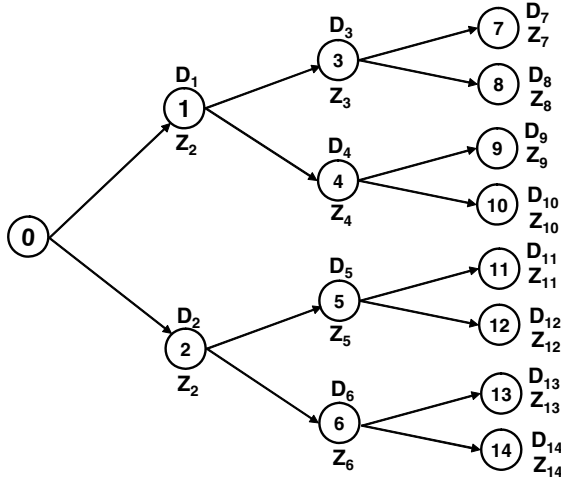

FIGURE 9.7 Three-Period Binomial Tree

$$\begin{aligned}
 a(3) &= a(4) = 1, & a(5) &= a(6) = 2 \\
 a(7) &= a(8) = 3, & a(9) &= a(10) = 4 \\
 a(11) &= a(12) = 5, & a(13) &= a(14) = 6 \\
 Z_n &= (Z_n^0, Z_n^1) & n &= 0, \dots, 14
 \end{aligned}$$

As in the two-period case, we chose a base case such that the average stock prices and demand values remain constant over the periods:

$$\begin{aligned}
 Z_0^1 &= \sum_{i=1}^2 Z_i^1 / 2 = \sum_{i=3}^6 Z_i^1 / 4 = \sum_{i=7}^{14} Z_i^1 / 8, \\
 \sum_{i=1}^2 D_i / 2 &= \sum_{i=3}^6 D_i / 4 = \sum_{i=7}^{14} D_i / 8
 \end{aligned}$$

The values of the parameters and the corresponding decision variables in the base case are shown in Table 9.6.

We now study the effect of following parameters on the value of the contract and option.

9.5.7 CASE 7: EFFECT OF SALES PRICE

The buyer sells the finished products at the end market to the customers at unit sales prices of r_1 , r_2 , and r_3 in period 1, 2, and 3, respectively. Figure 9.8 shows the impact of first period sales price (r_1) on the contract and option values. The

TABLE 9.6 Parameters and the Decision Variables in Base Case

Parameters	Decision Variables	Decision						
		n	Z_n^0	Z_n^1	D_n	θ_n^0	θ_n^1	F_n
		0	10.00	15		10.440	-60.223	
$r_t = 20$	$Q_1 = 40$	1	11.00	20	45	-71.663	-29.702	-292.5
$p_t = 12$	$V^0 = 353.70$	2	11.00	10	25	-23.363	-23.300	-2.5
$h_t = 1.5$	$V^M = 799.10$	3	12.10	25	55	23.479	-53.750	550.0
$s_t = 2.5$	$m_1 = 60$	4	12.10	5	30	-4.132	-80.625	562.5
$M = 100$	$m_3 = 65$	5	12.10	22	40	31.528	-76.786	-512.5
$e_t = 10$	$m_4 = 10$	6	12.10	8	15	28.174	-107.500	-50.0
		7	13.31	30	65			1300.0
	$m_5 = 75$	8	13.31	20	40			762.5
		9	13.31	8	35			700.0
	$m_6 = 35$	10	13.31	4	20			377.5
		11	13.31	25	50			1500.0
		12	13.31	18	25			962.5
			13	13.31	10	35		
		14	13.31	5	10			162.5

contract value obviously increases with r_1 , as the end product sales bring more revenue to the buyer. The option value, on the other hand, is decreasing in r_1 , as the buyer will ensure that the demands are satisfied with firm orders in period 1 with a higher probability, thus will exercise fewer options at the beginning of period 1. After a threshold value of r_1 , the option value does not change, since the buyer does not use any options to satisfy period 1 demand after this threshold.

9.5.8 CASE 8: EFFECT OF HOLDING COST

Inventory holding cost rate has a direct effect on contract and option values. Figure 9.9 shows the impact of holding cost rate in period 1 (h_1). As h_1 increases,

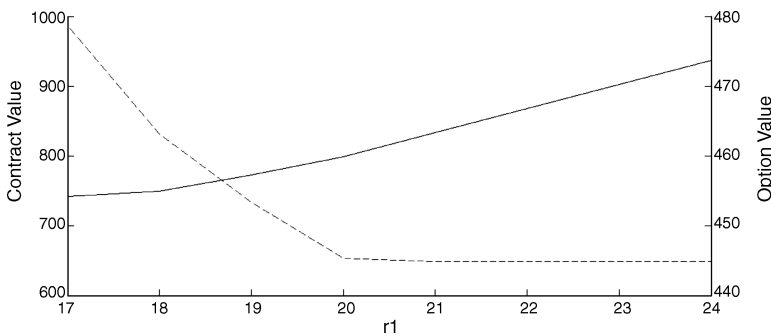

FIGURE 9.8 Contract and Option Values vs Sales Price of Period 1

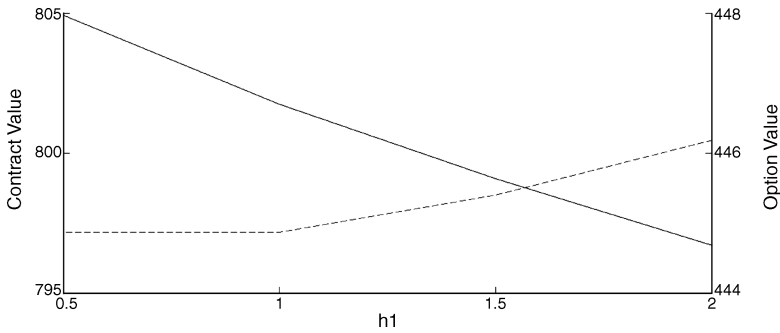

FIGURE 9.9 Contract and Option Values vs Holding Cost of Period 1

the contract value obviously decreases, since the buyer incurs more cost for excess inventory. On the other hand, the option value increases since the buyer prefers to use options instead of placing firm orders and carrying inventory to satisfy demand.

A similar result is shown in Figure 9.10, where the inventory holding cost rates in periods 2 and 3 are changed.

9.5.9 CASE 9: EFFECT OF STOCK-OUT COST

If the buyer cannot satisfy the demand in a given period, he incurs a stock-out cost. Therefore, the stock-out costs has an immediate effect on the value of the contract and the option value. Figure 9.11 shows the impact of the period 1 stock-out cost on the contract and option value. As expected, the contract value decreases with an increase in stock-out cost. However, we also see a decrease in the option value. This happens since the buyer places more firm orders in order to avoid stock-outs and thus needs less options when the stock-out

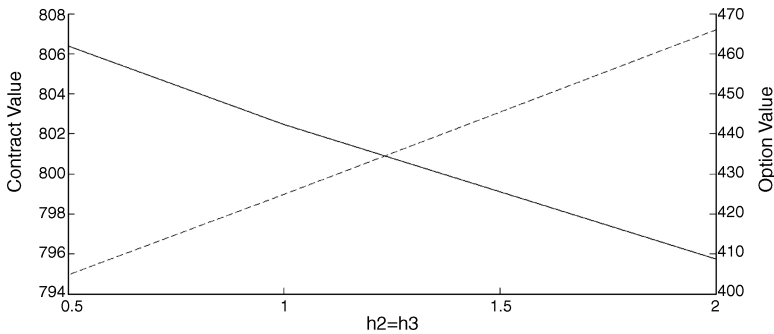

FIGURE 9.10 Contract and Option Values vs Holding Cost of Period 2-3

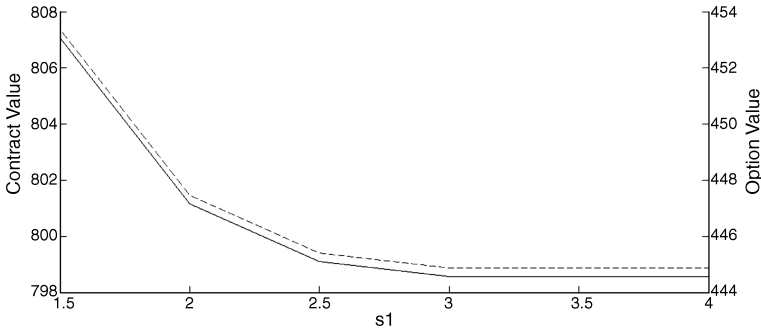

FIGURE 9.11 Contract and Option Values vs Stock-out Cost of Period 1

cost is high (Remember that the options that are exercised lead to deliveries next period).

9.6 Conclusion

In this chapter, we considered a general single buyer—single supplier quantity flexibility contract with options for multiple periods. We investigated the problem of the buyer of the contract under the assumption that the markets evolve as discrete scenario trees, and gave a linear optimization model to compute the maximum acceptable price of the contract for the buyer by analyzing both financial and real markets. Since the relationship between various parameters in the model can be quite intricate to analyze, an experimental study for parameter shifts, which are too complicated for analysis, was also presented. The model is flexible enough to accommodate incomplete financial markets, markets with frictions (transaction costs and taxes), and risk aversion attitudes of the buyer. Future research will extend the model to the aforementioned cases as well as the interesting case of partial correlation of the demand and the price of the risky security.

REFERENCES

- Barnes-Schuster D., Bassok Y., Anupindi R. 2002. Coordination and flexibility in supply contracts with options. *Manufacturing and Service Operations Management*, **4**:171–207.
- Bartram S.M., Brown G.W., Fehle F.R. 2009. International evidence on financial derivatives usage. *Financial Management*, **38**:185–206.
- Bassok Y., Srinivasan R., Bixby A., Wiesel H. 1997. Design of component supply contracts with commitment revision flexibility. *IBM Journal of Research and Development*, **41**:693–703.

- Black F., Scholes M. 1973. The pricing of options and corporate liabilities. *Journal of Political Economy*, **81**:637–654.
- Burnetas A., Ritchken P. 2005. Option pricing with downward-sloping demand curves: The case of supply chain options. *Management Science*, **51**:566–580.
- Cachon G. 2003. Supply chain coordination with contracts. In: Graves C.S., de Kok T., editors. *Handbooks in Operations Research & Management Science: Supply Chain Management*. North Holland.
- Cachon G. 2005. Supply chain coordination with revenue-sharing contracts: Strengths and limitations. *Management Science*, **51**:30–44.
- Cachon G., Lariviere M.A. 2001. Contracting to assure supply: How to share demand forecasts in a supply chain. *Management Science*, **47**:629–646.
- Caldentey R., Haugh B.M. 2009. Supply contracts with financial hedging. *Operations Research*, **57**:47–65.
- Chen F., Parlar M. 2007. Value of a put option to the risk-averse newsvendor. *IIE Transactions* **39**:481–500.
- Cheng F., Ettl M., Lin G.Y., Schwarz M., Yao D. 2006. Designing flexible supply chain contracts via options. Technical report. Yorktown Heights, New York: IBM Thomas J. Watson Research Center.
- Delft van Ch., Vial J.Ph. 2004. A practical implementation of stochastic programming: An application to the evaluation of option contracts in supply chains. *Automatica*, **40**:743–756.
- Ding Q., Dong L., Kouvelis P. 2007. On the integration of production and financial markets in global markets. *Operations Research*, **55**:470–489.
- Edirisinghe C., Naik V., Uppal R. 1993. Optimal replication of options with transaction costs and trading restrictions. *Journal of Financial and Quantitative Analysis*, **28**:117–138.
- Eppen G., Iyer E. 1997. Backup agreements in fashion buying—the value of upstream flexibility. *Management Science*, **43**:1469–1484.
- Gaur V., Seshadri S. 2005. Hedging inventory risk through market instruments. *Manufacturing and Service Operations Management*, **7**:103–120.
- Harrison J.M., Pliska S.R. 1981. Martingales and stochastic integrals in the theory of continuous time trading. *Stochastic Processes and Their Applications*, **11**: 215–260.
- King, A.J. 2002. Duality and martingales: A stochastic programming perspective on contingent claims. *Mathematical Programming* **91**:543–562.
- Lee H.L., Padmanabhan V., Taylor T.A., Whang S. 2000. Price protection in the personal computer industry. *Management Science*, **46**:467–482.
- Li H., Ritchken P., Wang Y. 2009. Option and forward contracting with asymmetric information: Valuation issues in supply chains. *European Journal of Operational Research*, **197**:134–148.
- Padmanabhan V., Png I.P.L. 1995. Returns policies: Make money by making good. *Sloan Management Review*, **37**:65–72.
- Pasternack B.A. 1985. Optimal pricing and return policies for perishable commodities. *Marketing Science*, **4**:166–176.
- Ritcken P.H., Tapiero C.S. 1986. Contingent claims contracting for purchasing decision in inventory management. *Operations Research*, **34**:864–870.

- Serel D.A., Dada M., Moskowitz H. 2001. Sourcing decisions with capacity reservation contracts. *European Journal of Operational Research*, **131**:635–648.
- Tsay A., Nahmias S., Agrawal N. 1998. Modeling supply chain contracts: A review. In: Magazine M., Tayur S., Ganeshan R., editors. *Quantitative Models for Supply Chain Management*. Kluwer Academic Publishers.
- Tsay A.A. 1999. The quantity flexibility contract and supplier–customer incentives. *Management Science*, **45**:1339–1358.
- Tsay A.A. 2002. Managing retail channel overstock: Markdown money and return policies. *Journal of Retailing*, **77**:457–492.