

# ENTANGLEMENT IN ATOM-PHOTON SYSTEMS

A DISSERTATION SUBMITTED TO  
THE DEPARTMENT OF PHYSICS  
AND THE INSTITUTE OF ENGINEERING AND SCIENCE  
OF BILKENT UNIVERSITY  
IN PARTIAL FULFILLMENT OF THE REQUIREMENTS  
FOR THE DEGREE OF  
DOCTOR OF PHILOSOPHY

By  
Muhammet Ali Can  
October, 2004

I certify that I have read this thesis and that in my opinion it is fully adequate, in scope and in quality, as a dissertation for the degree of doctor of philosophy.

---

Prof. Dr. Alexander S. Shumovsky(Supervisor)

I certify that I have read this thesis and that in my opinion it is fully adequate, in scope and in quality, as a dissertation for the degree of doctor of philosophy.

---

Prof. Dr. Metin Gürses

I certify that I have read this thesis and that in my opinion it is fully adequate, in scope and in quality, as a dissertation for the degree of doctor of philosophy.

---

Assoc. Prof. Dr. Ahmet Oral

I certify that I have read this thesis and that in my opinion it is fully adequate, in scope and in quality, as a dissertation for the degree of doctor of philosophy.

---

Prof. Dr. Namık Kemal Pak

I certify that I have read this thesis and that in my opinion it is fully adequate, in scope and in quality, as a dissertation for the degree of doctor of philosophy.

---

Prof. Dr. Tarık Çelik

Approved for the Institute of Engineering and Science:

---

Prof. Dr. Mehmet B. Baray  
Director of the Institute

# ABSTRACT

## ENTANGLEMENT IN ATOM-PHOTON SYSTEMS

Muhammet Ali Can

PhD in Physics

Supervisor: Prof. Dr. Alexander S. Shumovsky

October, 2004

In this work we propose a new principle from the point of view of quantum fluctuations of observables. This new principle can be considered as an operational definition of ME states. Moreover, we show the existence of perfect entangled states of a single “spin-1” particle. We give physical examples related to the photons, and particle physics. We show that a system of  $2n$  identical two-level atoms interacting with  $n$  cavity photons manifests entanglement and that the set of entangled states coincides with the so-called  $SU(2)$  phase states. In particular, violation of classical realism in terms of Greenberger-Horne-Zeilinger (GHZ) and Clauser-Horne-Shimony-Holt (CHSH) conditions is proved. We also show that generation of entangled states in the atom-photon systems under consideration strongly depends on the choice of initial conditions

In order to obtain maximally robust entangled states we have combined maximum principle with minimum of energy requirement for stabilization, called *Mini-max principle*. We discuss the generation and monitoring of durable atomic entangled state via Raman-type process, which can be used in the quantum information processing. It is shown that the system of two three-level atoms in  $\Lambda$  configuration in a cavity can evolve to a long-lived maximum entangled state if the Stokes photons vanish from the cavity by means of either leakage or damping.

We presented some results based on the application of spherical wave representation to description of quantum properties of multipole radiation generated by atomic transitions. In particular, the angular momentum of photons including the angular momentum entanglement, the quantum phase of photons, and the spatial properties of polarization are discussed.

*Keywords:* Quantum Information Theory, Cavity Quantum Electrodynamics, Entanglement, Maximally Entangled States, Mini-max Principle, Robust entanglement, Multipole Radiation, Angular Momentum of Photons .

# ÖZET

## ATOM-FOTON SİSTEMLERİNDE DOLAŞIKLIK

Muhammet Ali Can

Fizik, Doktora

Tez Yöneticisi: Prof. Dr. Alexander S. Shumovsky

Ekim, 2004

Bu çalışmada kuvantum dalgalanmaları bakış açısından yeni bir prensip önerildi. Bu yeni prensip maksimum dolaşık durumların işlevsel tanımı olarak ele alınabilir. İlaveten spin-1 tek bir parçacığın da maksimum dolaşık durumda olabileceği gösterilmektedir. Bu durum fotonlar ve parçacık fiziği için örneklendi.  $2N$  sayıdaki iki seviyeli atom ve  $N$  fotonlu bir oyukta(odacık) atom-foton etkileşimi sonucu oluşan dolaşık durumların  $SU(2)$  faz durumlarıyla örtüştüğünü gösterdik. Özel olarak klasik gerçelliğin yadsınması Greenberger-Horne-Zeilinger(GHZ) ve Clauser-Horne-Shimoni-Holt(CHSH) koşullarına uygun olarak gösterildi. Bunun ötesinde atom-foton sistemlerinde dolaşık durumların üretimi başlangıç durumuna bağlıdır.

Maksimum dolaşık durağan durumların yaratılması, maksimum dolaşıklık ve minimum enerji koşullarının sağlanmasıyla Minimum-maksimum prensibini elde ettik. Raman tipi süreçlerle, kuvantum bilgi işlemlenmesinde kullanılmaya uygun durağan dolaşık durumların yaratılması ve gözlemlenmesini tartıştık. İki Lambda tipi atomun oyukta Stokes fotonların emilimi ya da oyuktan kaçması sonucu uzun ömürlü maksimum dolaşık duruma ulaşabileceği gösterildi.

Küresel dalgalar kullanarak, atomik geçişler sonucu oluşan çok kutuplu ışınımın kuvantum özellikleriyle ilgili bir takım yeni sonuçlar sunulmuştur. Özel olarak fotonların açısal momentumu ve dolaşık açısal momentum durumları, faz ve polarizasyon özellikleri ele alındı.

*Anahtar sözcükler:* Kuvantum Bilgi Teorisi, Oyuk Kuvantum Elektrodinamiği, Dolaşıklık, Maksimum Dolaşık Durumlar, Mini-maks Prensibi, Kalıcı Dolaşıklık, Çok Kutuplu Radyasyon, Fotonların Açısal Momentumu .

# Acknowledgement

I would like to express my deepest gratitude to *Prof. Alexander S. Shumovsky* for his supervision, guidance and understanding throughout this thesis during last six years.

I would like to thank to my co-authors Prof. Alexander Klyachko, Özgür Çakır, Ali Can Günhan and Öney Soykal for their invaluable contributions and my friends Kerim Savran, Feridun Ay, İsa Kiyat, Sefa Dağ and Rasim Dermez for their continuous help and moral support.

I would like to express my endless thanks to my family for their moral supports. My princess Ayşe, thank you for your endless support, you are so precious and unique.

# Contents

<b>1</b>	<b>Introduction</b>	<b>1</b>
<b>2</b>	<b>Entanglement of Qubits</b>	<b>5</b>
2.1	Bits and Qubits . . . . .	5
2.2	Density Matrix . . . . .	7
2.2.1	Reduced Density Matrix . . . . .	8
2.3	Entanglement of Qubits . . . . .	8
2.4	Information Entropy . . . . .	10
2.5	Concurrence . . . . .	11
2.6	Some Physical Realizations of Qubits . . . . .	13
2.6.1	Spin- $\frac{1}{2}$ qubits . . . . .	13
2.6.2	Two Level Atoms . . . . .	15
2.6.3	Polarization States of a Photon . . . . .	16
2.7	Summary . . . . .	16
<b>3</b>	<b>Maximum Principle For Entanglement</b>	<b>18</b>

3.1	Maximum Principle . . . . .	18
3.1.1	single qubit case . . . . .	23
3.1.2	2-qubits case . . . . .	23
3.1.3	single qutrit case . . . . .	25
3.2	Maximum Principle and $SU(2)$ Phase States for Qubits . . . . .	29
3.2.1	Entanglement of 2-level atoms . . . . .	30
3.2.2	Representation of the $SU(2)$ phase states . . . . .	31
3.2.3	An example . . . . .	35
3.2.4	Effect of Initial Conditions on Atomic Entanglement . . . . .	39
3.3	Summary . . . . .	43
<b>4</b>	<b>Mini-max Principle for Robust Entanglement</b>	<b>44</b>
4.1	Mini-max Principle . . . . .	45
4.2	An Example: Entanglement of two $\Lambda$ -type atoms . . . . .	46
4.3	Summary . . . . .	52
<b>5</b>	<b>Entanglement of Photons</b>	<b>53</b>
5.1	Introduction . . . . .	53
5.2	Quantization of Multipole Radiation . . . . .	55
5.3	Angular Momentum of Multipole Photons . . . . .	60
5.4	Quantum Phase of Electric Dipole (E1) Photons . . . . .	67
5.5	Polarization of Multipole Photons . . . . .	72



5.6 Summary . . . . . 77

**6 Conclusions** . . . . . **79**

# List of Figures

1.1	Two two-level atoms in a single mode leaky cavity, proposed in Ref.[4] . . . . .	2
2.1	Visualization of a Qubit in Bloch sphere . . . . .	14
2.2	Energy levels of a two level atom . . . . .	15
4.1	Scheme of Raman-type process in an atom. Solid arrows show the allowed transitions. Wavy lines show the pump and Stokes photons, respectively. . . . .	48
4.2	Scheme of creation of a durable two-atom entanglement. Atom 1 is trapped in a cavity, while atom 2 can pass through the cavity. Wavy lines show the cavity and leaking out Stokes photons. . . . .	49
5.1	Energy diagram of triple degenerated excited and ground states of a dipole transition $j = 1 \leftrightarrow j' = 0$ . . . . .	61
5.2	Generation of two E1 type photons from an atomic transition, $j = 2 \rightarrow j' = 0$ . . . . .	66

# Chapter 1

## Introduction

The notion of entanglement lies in the very heart of quantum information, which is a modern branch of science based on quantum mechanics and information theory. In particular, the use of quantum information protocols can lead to an unprecedented security of communication channels and high speed of computations.

The two main problems related to the entanglement are on the one hand to describe entanglement quantitatively as a physical phenomenon and to find conditions under which entanglement becomes robust. These problems are discussed in the present Thesis. The main physical objects, that we discuss in the context of realization of entangled states, are atoms and photons.

Atoms and ions, interacting with cavity photons, are basic building blocks of quantum information processing. At least, they represent a useful tool for testing quantum algorithms in communications, cryptography, and computing [1, 2]. Realization of different quantum information processes, such as teleportation [3], requires perfect (maximum) and long-lived (robust) entangled states. In general, two-level atoms are used for realization of entangled states. Unfortunately, the lifetime of entanglement in atomic systems is mostly specified by the lifetime of excited atomic states with respect to dipole transitions and therefore is quite short.

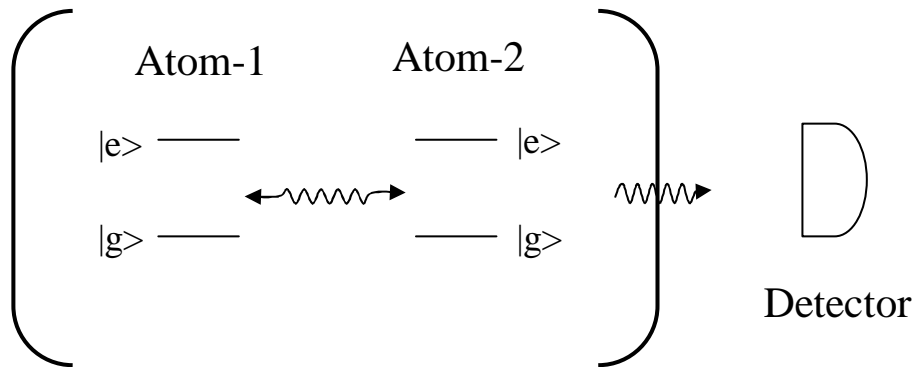

Figure 1.1: Two two-level atoms in a single mode leaky cavity, proposed in Ref.[4]

An interesting proposal has been made in Ref.[4] (for further discussion, see Refs. [5] and [6]). It was shown that a pure entangled state of two atoms in an optical resonator can be obtained through the exchange by a single photon (see Fig.(1.1)). Since the excitation of the system either is carried by a cavity photon or is shared between the atoms, the absence of the photon leakage from the resonator can be associated with the presence of atomic entanglement. This entanglement can be observed in the process of continuous monitoring of the cavity decay [4]. The importance of this scheme is caused by the fact that its realization seems to be easy available with present experimental technique. The result can also be generalized on the multi-atom systems [6].

In view of the practical realization, it seems to be more convenient if the existence of atomic entanglement would manifest itself via a certain signal photon rather than via the absence of photons. This implies that there should be at least two different modes interacting with the atoms such that the photon of one of them provides the correlation between the atoms, while the photon of the other mode can freely leave the resonator to signalize the rise of atomic entanglement. This leads to the idea of  $\Lambda$ -type atoms instead of two level atoms. As we will see in proceeding chapters, it is much more practical than the previous scheme.

Two-photon entangled states are the most popular and practical realizations for fundamental and applied physics [7]. They are generated by a nonlinear crystal or by a quadrupole transition from an atom. It is well known that the atomic

and molecular transitions emit the multipole radiation represented by spherical electromagnetic waves [8]. In classical picture, either plane or spherical waves can be used since both of them form the complete orthogonal sets of solutions of the wave equation. However, in quantum picture, there is a fundamental difference between these two representations of electromagnetic field. First of all, the plane waves of photons correspond to the states of the field with given linear momentum. At given wave number  $k$ , they are specified by only four operators of creation and destruction with two different polarizations [9, 10]. At the same time, the spherical waves of photons correspond to the states with given angular momentum. At given  $k$ , total angular momentum  $j \geq 1$  and parity, they are specified by  $2(2j + 1) \geq 6$  different operators of creation and destruction [10, 11]. Since the components of linear and angular momenta do not commute with each other, the two representations correspond to the physical observables, which cannot be measured simultaneously. Therefore, in order to describe the quantum multipole radiation, we have to deal with the spherical waves of photons rather than plane waves [10]. The quantum properties of multipole radiation important for quantum information processing are discussed in this Thesis.

The Thesis is organized as follows.

First, we summarize some introductory concepts for developments of *Quantum Information Theory* such as qubits, density matrix, reduced density matrix, entanglement, information entropy, reduced information entropy and concurrence. Then we give some physical realizations for qubits based on two level atoms, spin- $\frac{1}{2}$  states and photon polarizations.

In the third chapter, we discuss variational principle for definition of completely entangled states, which is based on the idea that complete entanglement is a manifestation of quantum fluctuations at their extreme. Next, we use the phase states of the SU(2) algebra to describe the maximally entangled states of qubits.

In the fourth chapter, we consider a certain *Mini-max Principle* that can be used to stabilize the entangled states. As an example of some considerable interest, we examine the system of two- $\Lambda$  type atoms in a cavity.

In the fifth chapter, we consider quantum properties of multipole photons important for quantum information processing, such as polarization, angular momentum, and orbital part of the angular momentum. We also discuss the possibility of creation of entangled photon pairs and single-particle entanglement.

Finally, at the last chapter, we summarize the obtained results.

# Chapter 2

## Entanglement of Qubits

In this chapter, as an introduction, I will summarize the necessary concepts for the development of quantum information theory starting from the definition of qubit. Next I will give some examples about physical realizations of qubits in various systems like polarization of photons, spin systems and atomic levels.

### 2.1 Bits and Qubits

The fundamental indivisible notion of classical information theory is a *BIT* which is  $0$  or  $1$ , false or true. Every computational tasks are done on the collection of these fundamental ingredients. The corresponding unit of quantum information theory is called the *Quantum Bit* or *QUBIT*. Although classical bit can only take either  $0$  or  $1$ , a quantum bit can take both with some probability. Actually it is a representation of a physical system in the two dimensional Hilbert space  $\mathbf{H}_2$  with basis  $\{|0\rangle, |1\rangle\}$ . The most general state (vector) in this two dimensional Hilbert space is a linear superposition of base vectors with complex coefficients,

$$|\psi\rangle = a|0\rangle + b|1\rangle \tag{2.1}$$

where  $|a|^2 + |b|^2 = 1$  conserves the probabilities. A qubit can contain any value of coefficients  $a$  and  $b$  in Eq(2.1).

Another possible way to describe a two dimensional Hilbert space is to use vector-column notations. For this aim, we can map our basis to the following orthogonal and normalized vectors

$$|0\rangle \longleftrightarrow \begin{pmatrix} 1 \\ 0 \end{pmatrix}, |1\rangle \longleftrightarrow \begin{pmatrix} 0 \\ 1 \end{pmatrix}. \quad (2.2)$$

One of the main differences between classical and quantum bits is that in quantum domain we cannot measure a qubit without disturbing it. In quantum mechanical language, measurement is projection of the unknown qubit onto the basis  $\{|0\rangle, |1\rangle\}$ . Then, the probability to obtain  $|0\rangle$  is  $|a|^2$  and for  $|1\rangle$  it is  $|b|^2$ . After the measurement, the state of the quantum system is in one of the measurement bases.

Because of the superposition principle in quantum mechanics, the power of quantum information increases with the number of qubits. For N-qubit system, we have tensor product of two-dimensional Hilbert spaces  $\mathbf{H} = \bigotimes_{n=1}^N \mathbf{H}_2$  with the basis  $\{|0\dots 0\rangle, |0\dots 01\rangle, |0\dots 10\rangle, |0\dots 11\rangle, \dots, |1\dots 1\rangle\}$ , which can also be written as  $\{|0\rangle_N, |1\rangle_N, \dots, |2^N - 1\rangle_N\}$  in binary basis. Then, the most general N-qubit state can be written as

$$|\psi\rangle = \sum_{x=0}^{2^N-1} a_x |x\rangle_N \quad (2.3)$$

with the normalization condition  $\sum_x |a_x|^2 = 1$  over complex numbers  $a_x$ . Now the probability to get  $|x\rangle_N$  is  $|a_x|^2$ .

In order to generalize N-qubit system into matrix notation we should follow the tensor product rule for two qubit system

$$\begin{pmatrix} x_0 \\ x_1 \end{pmatrix} \otimes \begin{pmatrix} y_0 \\ y_1 \end{pmatrix} = \begin{pmatrix} x_0 y_0 \\ x_0 y_1 \\ x_1 y_0 \\ x_1 y_1 \end{pmatrix}. \quad (2.4)$$



## 2.2 Density Matrix

Representation of a quantum system as a state vector in a Hilbert Space is a complete description of its physical properties however this is not always possible. Most of the times the state of the system is not known precisely, and usually we are interested in a small subsystem of a larger system. This is always true when we have an open quantum system, where the system of interest is interacting with a larger system called *environment*. Then, our subsystem is a part of a bigger system, and we cannot represent its state as a state vector. We need another object called density matrix representation. For a pure state, density matrix can be defined as

$$\rho = |\psi\rangle\langle\psi| \quad (2.5)$$

and due to the normalization condition  $\langle\psi|\psi\rangle = 1$ ,

$$\text{Tr}\rho = 1. \quad (2.6)$$

Expectation value of any operator acting globally in the space of the system can be written as

$$\langle A \rangle = \langle\psi|A|\psi\rangle = \text{Tr}(A\rho) = \text{Tr}(\rho A). \quad (2.7)$$

It is clear that every measurable information is included in the density matrix representation, therefore it is an physically equivalent representation to the state vector formalism.

If we know that the state of the system is prepared with some probability  $p_k$  in various states  $|\psi_k\rangle$ , then we can write the density matrix as

$$\rho = \sum_k p_k |\psi_k\rangle\langle\psi_k|. \quad (2.8)$$

In this case, expectation value of an operator is

$$\langle A \rangle = \sum_k p_k \langle\psi_k|A|\psi_k\rangle = \text{Tr}(A\rho). \quad (2.9)$$

Note here that probabilities enter two times in Eq(2.9), quantum ( $\langle\psi_k|A|\psi_k\rangle$ ) and statistical ( $p_k$ ) probabilities. Such states are called *mixed states*.

There are some properties of density matrix;

- $\rho$  is Hermitian;  $\rho = \rho^\dagger$ ,
- $\rho$  is positive semi-definite; for any  $|\psi\rangle$ ,  $\langle\psi|\rho|\psi\rangle \geq 0$ ,
- $Tr\rho = 1$  and  $Tr\rho^2 \leq 1$ , equality holds for pure states,

### 2.2.1 Reduced Density Matrix

Assume that we have two systems  $A$  and  $B$  with orthonormal and complete bases  $\{|a_i\rangle\}$  and  $\{|b_j\rangle\}$  in Hilbert spaces  $\mathbf{H}_A$  and  $\mathbf{H}_B$ . The Hilbert space of this bipartite system  $\mathbf{H}_A \otimes \mathbf{H}_B$  has basis  $\{|a_i\rangle \otimes |b_j\rangle\}$ . Then, any pure state can be written as

$$|\psi\rangle_{AB} = \sum_{i,j} c_{ij} |a_i\rangle \otimes |b_j\rangle \quad (2.10)$$

with normalization condition  $\sum_{i,j} |c_{ij}|^2 = 1$ . Now, the expectation value of an observable acting only one of the subsystem A is

$$\begin{aligned} \langle \mathcal{O}_A \otimes \mathbf{I}_B \rangle &= {}_{AB} \langle \psi | \mathcal{O}_A \otimes \mathbf{I}_B | \psi \rangle_{AB} \\ &= \sum_{i,j,i',j'} c_{ij}^* c_{i'j'} \langle a_i | \otimes \langle b_j | (\mathcal{O}_A \otimes \mathbf{I}_B) | a_{i'} \rangle \otimes | b_{j'} \rangle \\ &= \sum_{i,i',j} c_{ij}^* c_{i'j} \langle a_i | \mathcal{O}_A | a_{i'} \rangle \\ &= Tr(\mathcal{O}_A \rho_A), \end{aligned} \quad (2.11)$$

where

$$\begin{aligned} \rho_A &= Tr_B(|\psi\rangle_{AB} \langle \psi|) \\ &= \sum_{i,i',j} c_{ij}^* c_{i'j} |a_i\rangle \langle a_{i'}| \end{aligned} \quad (2.12)$$

is called reduced density matrix. There is partial trace over the complete basis of subsystem  $B$ . Reduced density matrix has the same properties of density matrices described in previous section.

## 2.3 Entanglement of Qubits

Entanglement is one of the most mysterious concepts in quantum world. It touches on the conceptual problems of reality and locality in quantum physics

as well as the more technological aspects of quantum communications, cryptography, and computing. In particular, the methods of quantum key distribution in communication channels secured from eavesdropping are based on the use of entangled states.

The term *verschränkt* is first used by *Schrödinger* Ref.[12] in German and translated to English as *entangled state* by himself. It became popular after the famous paper by Einstein, Podolsky and Rosen *Can Quantum mechanical description of physical reality be considered complete?* Ref.[13] is used as an objection to quantum reality of the nature. In turn, the realization of quantum computer, quantum communication, and quantum teleportation Ref.[14, 15, 16, 17, 18] depend on the ability to form entangled states of initially uncorrelated single-particle states. Non-classical correlations between the systems can be the signature for entanglement. We can simply define an entangled state as one, which cannot be represented as the product states of individual sub-systems or subspaces. Therefore, in general it is a property of multi-party systems. If there is no entanglement between the two parties, it cannot be created applying local operations. In addition the amount of entanglement cannot be changed via local unitary operations so that it is an invariant quantity under local transformations.

The most general 2-qubit state in a product Hilbert space  $\mathbf{H}_2 \otimes \mathbf{H}_2$  can be written as

$$|\psi\rangle = a|00\rangle + b|01\rangle + c|10\rangle + d|11\rangle. \quad (2.13)$$

Depending on the coefficients  $a, b, c, d$  this state can describe either an entangled state or not. For example if  $c = d = 0$ , then it reduces to  $a|00\rangle + b|01\rangle$  which can be written as  $|0\rangle \otimes (a|0\rangle + b|1\rangle)$ . In other words, the subsystem  $A$  can be factor out, which means that this state is unentangled one. However, if  $b = c = 0$ , then Eq(2.13) becomes  $a|00\rangle + d|11\rangle$ , which can not be written as a tensor product of its constituents, so it is an entangled state. Since the complex coefficients  $a, b, c, d$  are only limited with normalization condition, there are infinite number of entangled states in  $\mathbf{H}_2 \otimes \mathbf{H}_2$ . Historically the most famous and important example to entangled state is EPR states

$$|\phi^\pm\rangle_{AB} = \frac{1}{\sqrt{2}}(|00\rangle_{AB} \pm |11\rangle_{AB})$$

$$|\psi^\pm\rangle_{AB} = \frac{1}{\sqrt{2}}(|01\rangle_{AB} \pm |10\rangle_{AB}) \quad (2.14)$$

which form a basis for the four-dimensional Hilbert space,  $\mathbf{H}_2 \otimes \mathbf{H}_2$ . They are important, because the amount of entanglement is maximal for these states, which means that Bell inequalities Ref.[19] are maximally violated.

## 2.4 Information Entropy

Entropy of any probability distribution,  $p_1, p_2, \dots, p_n$  can be defined as

$$H(p_1, \dots, p_n) \equiv - \sum_x p_x \log p_x. \quad (2.15)$$

It is called the *Shannon entropy*, Ref.[20] which quantifies how much information is gained after the measurement or the amount of uncertainty about the measurement before we learn its value. In a sense, entropy quantify the lack of knowledge. If the system is in a definite state then, entropy is zero, but if we know nothing about the system, it is equally likely to find the system in any of its possible states so that entropy is maximum. Here we take  $0 \log 0 \equiv 0$ .

When we have binary outcomes for the measurements of the system, we can define binary entropy as

$$H(p) \equiv -p \log p - (1-p) \log(1-p) \quad (2.16)$$

where  $p$  and  $1-p$  are the probabilities of the outcomes. Binary entropy is maximal  $H(p) = 1$  when  $p = \frac{1}{2}$ , i.e. both outcomes are equally probable.

Quantum counterpart of the probability distribution is the density matrix. Then, the *Von Neumann entropy* Ref.[21, 22] is the corresponding quantity for Shannon entropy in quantum information theory. It is defined as

$$S(\rho) \equiv -\text{Tr}(\rho \log \rho) \quad (2.17)$$

where  $\rho$  is the density matrix of the system. In terms of the eigenvalues of the density matrix  $\lambda_x$  (represents the spectrum of  $\rho$ ) it can be re-written as

$$S(\rho) = - \sum_x \lambda_x \log_2 \lambda_x \quad (2.18)$$

Since it depends only on eigenvalues, it is invariant under unitary transformation of basis,  $S(U\rho U^{-1}) = S(\rho)$ . For a pure state  $\rho = |\varphi\rangle\langle\varphi|$ , whether it is entangled or not in a  $n$ -dimensional space,  $S(\rho) = 0$  meaning that there is no uncertainty in the knowledge of the system. Everything is known. If we have completely mixed state  $\rho = I/n$  in  $n$ -dimensional space, then  $S(\rho) = \log n$ , that is our knowledge about the system is minimal.

What happens when we measure only one of the subsystems of the whole system? To do this we insert reduced density matrices in the Von Neumann entropy formula Eq(2.17). Let's first do this for a separable state for 2-qubits,  $|\psi\rangle = |00\rangle_{AB}$ . Here total density matrix of the whole system is  $\rho = |00\rangle\langle 00|$ , but the reduced density matrix for the sub-system  $A$  is  $\rho_A = \text{Tr}_B \rho = \langle 0|\rho|0\rangle_B + \langle 1|\rho|1\rangle_B$ . If we calculate the entropy,  $S(\rho_A) = S(\rho_B) = 0$ . This means that there is no uncertainty about the information of the system whether we measure only one of its subsystems,  $A$  or  $B$ . They are called uncorrelated systems. Now we can repeat the same calculation for one of the maximally entangled states in Eq(2.14) and we get  $\rho_A = \rho_B = \frac{1}{2}I_{2\times 2}$  for reduced density matrices. It is clear that although the combined system  $AB$  is in a pure state, the reduced density matrices are in completely mixed states so that  $S(\rho_A) = S(\rho_B) = \log_2 2 = 1$ . In other words we have maximum uncertainty about the whole system  $AB$  when we only measure the sub-systems. We cannot extract any information about the whole system by only looking at its subsystem. Rather the information is encoded in the nonlocal quantum correlations.

## 2.5 Concurrence

Two qubit entanglement is very well understood, moreover there is a successful measure of entanglement called *Concurrence or Entanglement of formation (a function of Concurrence)* Ref.[24, 25], describing the amount of entanglement in the system. Its aim is to quantify the amount of quantum communication necessary to create a given quantum state. Any measure of entanglement should satisfy some properties. One of them is that it should be invariant under local

transformations. Concurrence of a state described by density matrix  $\rho$  has the form

$$C(\psi) = \text{Max}\{0, \lambda_1 - \lambda_2 - \lambda_3 - \lambda_4\} \quad (2.19)$$

where  $\lambda_i$ 's are square roots of eigenvalues of  $\rho\tilde{\rho}$  in descending order  $\lambda_1 > \lambda_2 > \lambda_3 > \lambda_4$ . Here  $\tilde{\rho} = (\sigma_y \otimes \sigma_y)\rho^*(\sigma_y \otimes \sigma_y)$  and  $\sigma_y$  is one of the Pauli matrices and  $\rho^*$  is the complex conjugation of  $\rho$ . This definition of Concurrence is valid both for mixed ( $\text{Tr}\rho^2 < 1$ ) and pure states ( $\text{Tr}\rho^2 = 1$ ). For a pure state like in Eq(2.13), Concurrence can be written as Ref.[26]

$$C(\psi) = 2\sqrt{\det\rho_A} = 2|ad - bc|. \quad (2.20)$$

This can be proven using the definition of concurrence. Since it is a pure state  $\rho = \rho^* = |\psi\rangle\langle\psi|$  and  $\sigma_y = -i(|0\rangle\langle 1| - |1\rangle\langle 0|)$ . We obtain

$$(\sigma_y \otimes \sigma_y)|\psi\rangle = -(d|00\rangle - c|01\rangle - b|10\rangle + a|11\rangle).$$

Then

$$\rho\tilde{\rho} = 2(ad - bc) \begin{pmatrix} ad & -ac & -ab & aa \\ bd & -bc & -bb & ba \\ cd & -cc & -cb & ca \\ dd & -dc & -db & da \end{pmatrix}.$$

This matrix has only one nonzero eigenvalue,  $4(ad - bc)^2$ . After taking the square root of this, the concurrence can easily be found as in Eq(2.20). For the sake of simplicity, we take the coefficients  $a, b, c, d$  as real numbers.

For separable or unentangled states,  $\rho_{AB} = \rho_A \otimes \rho_B$ , concurrence,  $C = 0$ , and for completely entangled states like Bell states,  $C = 1$ . Although concurrence can be used as a measure of entanglement in the system, we can really check the amount of information in the system by looking the information entropy.

The entanglement of formation is a function of the concurrence. It is given as

$$E = H\left(\frac{1 + \sqrt{1 - C^2}}{2}\right) \quad (2.21)$$

where  $H$  is the binary entropy function in Eq(2.16). Entanglement of formation gives the same result as we get from the entropy of the reduced density matrices. In other words,  $E = S(\rho_A) = S(\rho_B)$ .

## 2.6 Some Physical Realizations of Qubits

As we indicated before, a qubit can be realized by any two level quantum system. Some examples can be a spin- $\frac{1}{2}$ , system like spin of an electron, ground and excited levels of an atom and polarization states of a photon. Now, let's consider them one by one.

### 2.6.1 Spin- $\frac{1}{2}$ qubits

For a realization of a qubit we need two distinct well separated and orthogonal levels to identify them with  $|0\rangle$  and  $|1\rangle$ . A spin- $\frac{1}{2}$  system has spin up  $|\uparrow\rangle$  and spin down  $|\downarrow\rangle$  states along one of the chosen axis like z-axis. Then any particular qubit Eq(2.1) with arbitrary coefficients can be described by a particular orientation of the spin in real space as

$$|\psi(\theta, \phi)\rangle = \begin{pmatrix} \cos \frac{\theta}{2} \\ \sin \frac{\theta}{2} e^{i\phi} \end{pmatrix}. \quad (2.22)$$

Here  $\theta$  and  $\phi$  describe the orientation of the qubit on a sphere called Bloch Sphere, Fig2.1. Every points on the surface of this sphere identifies a particular qubit. However this is not the only story. To see the correspondence, we should pass to the density matrix representation.

$$\begin{aligned} \rho(\theta, \phi) &= |\psi(\theta, \phi)\rangle\langle\psi(\theta, \phi)| \\ &= \begin{pmatrix} \cos \frac{\theta}{2} \\ \sin \frac{\theta}{2} e^{i\phi} \end{pmatrix} \begin{pmatrix} \cos \frac{\theta}{2} & \sin \frac{\theta}{2} e^{-i\phi} \end{pmatrix} \\ &= \frac{1}{2}I + \frac{1}{2} \begin{pmatrix} \cos \theta & \sin \theta e^{-i\theta} \\ \sin \theta e^{i\theta} & -\cos \theta \end{pmatrix} \\ &= \frac{1}{2}(I + \hat{n} \cdot \vec{\sigma}) \end{aligned} \quad (2.23)$$

where  $\hat{n} = (\sin \theta \cos \phi, \sin \theta \sin \phi, \cos \theta)$  identifies the point on the Bloch sphere. Every point on the surface of the sphere identifies a pure state of the qubit while points inside the sphere identify mixed states and for this case we can replace  $\hat{n}$

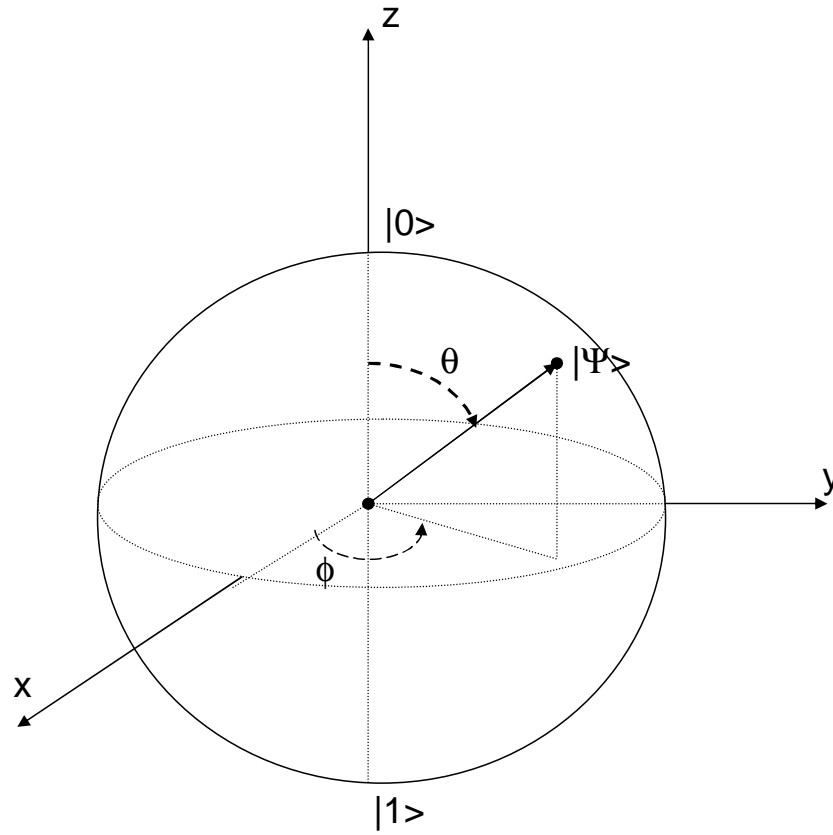

Figure 2.1: Visualization of a Qubit in Bloch sphere

with a vector  $\vec{P}$  identifying a point inside the sphere,  $0 < |\vec{P}| < 1$ . For mixed states, there can be a decomposition like

$$\rho(\vec{P}) = \lambda\rho(\hat{n}_1) + (1 - \lambda)\rho(\hat{n}_2), \quad (2.24)$$

if  $\vec{P} = \lambda\hat{n}_1 + (1 - \lambda)\hat{n}_2$ . Therefore there are infinitely many statistical combinations of pure states to result in a particular mixed state.

An applied magnetic field can rotate this orientation in desired way to realize the qubit gate operations which, is necessary in order to realize any quantum computation protocol.



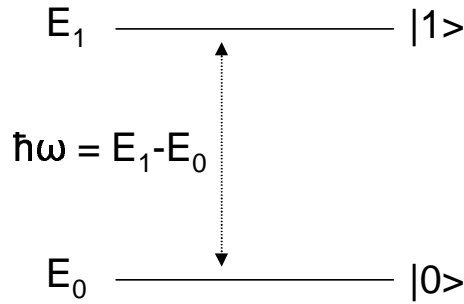

Figure 2.2: Energy levels of a two level atom

### 2.6.2 Two Level Atoms

It is well known that EM field, interacting with a two level atom, is mathematically equivalent to a spin- $\frac{1}{2}$  particle interacting with the field. This makes the two level atom one of the possible candidate for quantum computation. We can store information in a two level atom and process the information by applying unitary transformations; moreover, we can carry this information from one atom to another, using photon mediated interaction. Thus, photons are carriers of the information and atoms are the memory for storing the information.

Besides these advantageous, physical realization of a two level atom can be difficult. Normally, atoms have many electronic levels, but if we use a single mode (frequency) and very well defined energy for the field, we can select only two of these levels and use them for our purposes. In other words, there are only two limitations; conservation of energy and *selection rules*, i.e. conservation of angular momentum and parity.

The incident photon should have the energy close to the difference of the energy levels of atoms like in the Fig2.2.

$$\hbar\omega = E_1 - E_0.$$

Under the dipole approximation, from the expansion of  $\vec{r}$  in terms of spherical harmonics in the calculation of matrix elements of interaction Hamiltonian,  $\langle l_1, m_1 | \vec{r} | l_2, m_2 \rangle$ , we get that the matrix elements are nonzero only if

$\Delta m = m_2 - m_1 = \pm 1$  and  $\Delta l = l_2 - l_1 = \pm 1$ . This is the selection rule for the dipole interaction.

### 2.6.3 Polarization States of a Photon

Photon is another example of a two-level system since it has two independent polarizations (helicities). Photons are massless particles and have a propagation direction perpendicular to the  $\vec{E}$  and  $\vec{B}$  fields (in the case of plane waves). Therefore we can only talk about rotations about the direction of propagation. Since photons are massless particles, there is no rest frame. Therefore, we cannot talk about the properties of a general rotation like in the case of a massive particles.

There are linear and circular polarization of photons. We can call linear polarization states as  $|x\rangle$  (horizontal) and  $|y\rangle$  (vertical). Under the rotations about the axis of propagation, they transform as

$$\begin{pmatrix} |x'\rangle \\ |y'\rangle \end{pmatrix} = \begin{pmatrix} \cos \theta & \sin \theta \\ -\sin \theta & \cos \theta \end{pmatrix} \begin{pmatrix} |x\rangle \\ |y\rangle \end{pmatrix} \quad (2.25)$$

This  $2 \times 2$  matrix has eigenstates and eigenvalues as

$$\begin{aligned} |R\rangle &= \frac{1}{2} \begin{pmatrix} 1 \\ i \end{pmatrix} = \frac{1}{2}(|x\rangle + i|y\rangle), e^{i\theta} \\ |L\rangle &= \frac{1}{2} \begin{pmatrix} i \\ 1 \end{pmatrix} = \frac{1}{2}(i|x\rangle + |y\rangle), e^{-i\theta}. \end{aligned} \quad (2.26)$$

They are called right and left circular polarization states which are also the eigenstates of Pauli matrix  $\sigma_y = \begin{pmatrix} 0 & -i \\ i & 0 \end{pmatrix}$ . Then both linear and circular polarization states can be used as qubits.

## 2.7 Summary

In this chapter we have discussed some fundamental notions of quantum information theory such as qubits, density matrix, entanglement, information entropy

and concurrence. Some realizations of a single qubit is also discussed at the last part of this introductory chapter.

# Chapter 3

## Maximum Principle For Entanglement

In this chapter, I will summarize a new approach to maximum entangled states from the point of view of quantum fluctuations. In the second part, following the relation between two-level atoms and spin- $\frac{1}{2}$  systems and using the machinery of group theory, I will show the importance and advantageous of using SU(2) phase states for entangled two-level atomic systems.

### 3.1 Maximum Principle

Very often, the existence of entanglement is verified in terms of violation of Bell's inequalities and their generalizations Ref.[27, 28, 29, 30, 31, 32]. Another way is based on the use of Greenberger-Horne-Zeilinger (GHZ) theorem Ref.[33]. A possibility to introduce more general inequalities is also discussed (see Ref.[34]). It should be noted that the use of Bell's inequalities and their numerous generalizations demonstrate nothing but the nonexistence of hidden variables in quantum mechanics. Moreover, it is possible to say that the unique, general, and mathematically correct definition of entanglement still does not exist (e.g., see Ref.[34]).

An interesting approach has been proposed in Ref.[34]. Considering the state shared between Alice and Bob as a quantum communication channel, the authors concluded that the information in the case of entanglement is carried mostly by the correlations between the ends of the channel. These correlations manifest themselves by means of the local measurements on the sides of the channel.

The maximum (complete) entangled state corresponds to a pure state of a system and can be associated with the amount of quantum fluctuations in this state Ref.[6]. In particular, it was shown that the maximum entanglement can be defined to be the manifestation of quantum fluctuations at their extreme Ref.[35]. It should be stressed that entangled states are equivalent to the maximum entangled states to within a certain local transformation such as stochastic local transformations assisted by classical communications Ref.[36] and Lorentz transformations Ref.[37]

The main ideas of the approach developed in Ref.[35, 36, 37, 38] consist in the definition of the fundamental set of observables  $\{\mathcal{O}\}$ , specifying a given system  $S$  in the Hilbert space  $\mathbf{H}_S$ , and in the calculation of the total amount of fluctuations of those observables.

Consider an arbitrary quantum system  $S$  defined in the Hilbert space  $\mathbf{H}_S$ , spanned by the vectors

$$|0\rangle, \quad |1\rangle, \quad \dots \quad |d-1\rangle, \quad (3.1)$$

where  $d = \dim \mathbf{H}_S$ . Depending on the specification of the system  $S$ , this space may contain either the states of a single particle or the states of a composite system. In the latter case, the space  $\mathbf{H}_S$  is represented by a tensor product of the states, corresponding to the individual particles (bipartite or multipartite system). The results we are going to list below are independent of the specification of the system  $S$ .

The fundamental observables can be associated with the dynamic symmetry group  $G$  in  $\mathbf{H}_S$  Ref.[38, 39]. Namely, the fundamental observables form a basis of the Lie algebra  $\mathcal{L}$  such that  $G = \exp(\mathcal{L})$ . Since the observables should be

represented by the Hermitian operators, sometimes it is necessary to use the complexified Lie algebra  $\mathcal{L}^c = \mathcal{L} \otimes \mathbf{C}$  instead of  $\mathcal{L}$  because some certain symmetries of the quantum system  $S$  can be hidden, so that they can only manifest themselves in complexified algebra. An example is provided by the dynamical symmetry group  $SU(2)$  of the Hilbert space, when the observables are represented by the spin operators, forming an infinitesimal representation of the  $SL(2, \mathbf{C})$  algebra, which is known to be the complexification of the  $SU(2)$  algebra.

It should be stressed that the complexification of the dynamic symmetry group plays a very important role in the description of entanglement. In particular Stochastic Local Operations Assisted by Classical Communications (SLOCC) corresponds to the transformations  $g \in SL(2, \mathbf{C})$  Ref.[36].

For example, in the simplest case of a single qubit (spin- $\frac{1}{2}$  particle), the dynamic symmetry group of the two-dimensional Hilbert space  $\mathbf{H}_{1/2}$  is  $G = SU(2)$ , while the observables are given by the Pauli operators

$$\begin{cases} \sigma_x &= |0\rangle\langle 1| + H.c. \\ \sigma_y &= -i|0\rangle\langle 1| + H.c. \\ \sigma_z &= |0\rangle\langle 0| - |1\rangle\langle 1| \end{cases} \quad (3.2)$$

forming the two-dimensional representation of the Lie algebra  $\mathcal{L}^C = SL(2, \mathbf{C})$ . It is known that the corresponding group  $G^C = SL(2, \mathbf{C})$  represents the complexification of the dynamic symmetry group  $G = SU(2)$  of the two-dimensional Hilbert space of spin- $\frac{1}{2}$  system.

If the system consists of more than one qubit, the Lie algebra  $\mathcal{L}^C = SL(2, \mathbf{C})$  specifies the *local observables*, and the dynamic symmetry groups have the form

$$G = \prod_{k=1}^n SU(2), \quad G^C = \prod_{k=1}^n SL(2, \mathbf{C}),$$

where  $n$  denotes the number of qubits.

The quantum fluctuation of an observable  $\mathcal{O}_i$ , forming a basis of Lie algebra  $\mathcal{L}$ , in a state  $\psi \in \mathbf{H}_S$  is represented by the variance

$$V_i(\psi) = \langle \psi | \mathcal{O}_i^2 | \psi \rangle - \langle \psi | \mathcal{O}_i | \psi \rangle^2. \quad (3.3)$$

or

$$V_i(\rho) = \text{Tr}(\rho \mathcal{O}_i^2) - (\text{Tr}(\rho \mathcal{O}_i))^2 \quad (3.4)$$

for mixed states.

Then, the total amount of quantum fluctuations in a given state takes the form

$$V_{tot}(\psi) = \sum_i V_i(\psi). \quad (3.5)$$

This quantity is similar to the so-called skew information that has been introduced by Wigner Ref.[40] as a measure of knowledge with respect to the physical quantities, whose measurement requires the use of the macroscopic apparatuses.

By definition given in Ref.[35], the maximum entanglement in the system  $S$  corresponds to the maximum of the total amount of quantum fluctuations

$$V(\psi_{ME}) = \max_{\psi \in \mathbf{H}_S} V_{tot}(\psi) \quad (3.6)$$

or

$$V(\rho_{ME}) = \max_{\{\rho\}} V_{tot}(\rho). \quad (3.7)$$

for mixed states.

By construction, this condition expresses a *variational principle*, defining the ME states in the similar way with the equilibrium states in quantum statistical mechanics (principle of the maximum entropy). It is very easy to check that conventional ME states in qubit, qutrit, and so on systems obey the condition (3.6).

From the physical point of view, the above definition (3.6) aligns ME with the known phenomena of coherence and squeezing, which are also defined in terms of quantum fluctuations. In particular, the coherent states can be defined as those, manifesting the minimal amount of quantum fluctuations (minimal remoteness). Thus, the coherent and ME states represent the two opposite poles of the quantum world with respect to the classical description of a system - the maximally closed pole and the maximally remote pole, respectively.

This condition (3.6) is further simplified when the Lie algebra  $\mathcal{L}$  of the essential observables form a Casimir operator.

$$\sum_i \mathcal{O}_i^2 = \mathbf{C}. \quad (3.8)$$

In this case

$$V(\psi_{ME}) = \max_{\psi \in \mathbf{H}_S} V_{tot}(\psi) = \mathbf{C}$$

under the condition that

$$\langle \psi_{ME} | \mathcal{O}_i | \psi_{ME} \rangle = 0, \forall i, \quad (3.9)$$

or

$$Tr(\rho_{ME} \mathcal{O}_i) = 0, \forall i, \quad (3.10)$$

for maximally entangled mixed states.

This last conditions are very useful and operational comparing to the variation principle. It is the definition of maximally entangled states in terms of what can be measured. As an example for spin states there is always one or more Casimir operators. Therefore we can easily apply this conditions for such cases.

Before we begin to discuss some examples of the variational principle, it should be noted that from there could be different choices of observables, corresponding to a given Hilbert space. From the physical point of view, they correspond to the measurements we are going to perform over the system or its parts. For example, the system with 3-dimensional Hilbert space can be specified either by the dynamic symmetry group  $SU(3)$ , corresponding to the states of a three-level system, or by the dynamic symmetry  $SU(2)$ , corresponding to the spin-1 particle (qutrit). In the former case, the number of independent observables, provided by the independent generators of the  $SU(3)$  algebra, is equal to 8, while in the letter case there are only 3 independent observables, represented by the generators of the  $SU(2)$  algebra in three dimensions. Now lets consider some examples.



### 3.1.1 single qubit case

Since the definition of ME states (3.9) is independent of the specification of the system  $S$ , it should also be valid in the case of a single particle.

Consider first as an illustrative example the case of a single qubit, when an arbitrary pure state in  $\mathbf{H}_{1/2}$  can be represented in the following form

$$|\psi(1/2)\rangle = \sum_{\ell=0}^1 \psi_{\ell} |\ell\rangle, \quad \sum_{\ell=0}^1 |\psi_{\ell}|^2 = 1, \quad (3.11)$$

where  $|0\rangle$  and  $|1\rangle$  are the base states in  $\mathbf{H}_{1/2}$ . Since the measurements in this case are provided by the Pauli operators (3.2), the conditions (3.9) take the form

$$\begin{cases} \operatorname{Re}(\psi_0 \psi_1^*) & = 0 \\ \operatorname{Im}(\psi_0 \psi_1^*) & = 0 \\ |\psi_0|^2 - |\psi_1|^2 & = 0 \end{cases}$$

In view of the normalization condition in (11), these equations have only trivial solution  $\psi_0 = \psi_1 = 0$ . Thus, the ME state of a single qubit does not exist.

### 3.1.2 2-qubits case

For two level systems such as spin states of an electron, electronic levels of a two level atoms or polarization states of a photon etc. we have  $SU(2)$  or  $SL(2, \mathbb{C})$  algebra as an underlying symmetry. Then the fundamental or essential set of observables are the well known Pauli spin operators.

$$\begin{aligned} \sigma_x &= |0\rangle\langle 1| + |1\rangle\langle 0| = \begin{pmatrix} 0 & 1 \\ 1 & 0 \end{pmatrix}, \\ \sigma_y &= -i|0\rangle\langle 1| + i|1\rangle\langle 0| = \begin{pmatrix} 0 & -i \\ i & 0 \end{pmatrix}, \\ \sigma_z &= |0\rangle\langle 0| - |1\rangle\langle 1| = \begin{pmatrix} 1 & 0 \\ 0 & -1 \end{pmatrix}. \end{aligned} \quad (3.12)$$

They form an infinitesimal representation of the compact Lie algebra  $SL(2, C)$  and the Casimir operator is

$$\sum_{i=x,y,z} \sigma_i^2 = 3. \quad (3.13)$$

Now, let us derive the well known EPR states from the variational principle. Here there are two spin- $\frac{1}{2}$  particle. Then the Hilbert space is a direct product of two individual spaces or  $\mathbf{H}_{2 \otimes 2} = \mathbf{H}_2 \otimes \mathbf{H}_2$ . In this direct product space a most general pure state can be written as

$$|\psi\rangle = a|00\rangle + b|01\rangle + c|10\rangle + d|11\rangle \quad (3.14)$$

with the normalization condition  $|a|^2 + |b|^2 + |c|^2 + |d|^2 = 1$ . The dynamical symmetry group is  $G = SU(2) \times SU(2)$ . Therefore, there are, as a total, 6 observables, which are the Pauli matrices for each spin- $\frac{1}{2}$  particle. The maximum of the total variance for  $N$  spin- $\frac{1}{2}$  particles is

$$\max_{\psi} V_{tot}(\psi) = 3N \quad (3.15)$$

and for two qubits case  $N = 2$ .

Applying the condition Eq.(3.9) gives

$$\begin{aligned} Re(ac^*) + Re(bd^*) &= 0 \\ Re(ab^*) + Re(cd^*) &= 0 \\ Im(ac^*) + Im(bd^*) &= 0 \\ Im(ab^*) + Im(cd^*) &= 0 \\ |a|^2 + |b|^2 - |c|^2 - |d|^2 &= 0 \\ |a|^2 - |b|^2 + |c|^2 - |d|^2 &= 0. \end{aligned}$$

The well known EPR-states are one of the solutions of these set of equations. In general, there are infinitely many solutions for  $N \geq 2$  qubits and all of them are maximally entangled states.

Another set of maximally entangled states forming a basis and obeying the condition Eq.(3.9)is

$$\frac{1}{2}(-|00\rangle + |01\rangle + |10\rangle + |11\rangle),$$

$$\begin{aligned}
& \frac{1}{2}(|00\rangle - |01\rangle + |10\rangle + |11\rangle), \\
& \frac{1}{2}(-|00\rangle + |01\rangle - |10\rangle + |11\rangle), \\
& \frac{1}{2}(-|00\rangle + |01\rangle + |10\rangle - |11\rangle)
\end{aligned} \tag{3.16}$$

For both of the above states concurrence is 1. The relation between concurrence and variational definition of entanglement is

$$C(\psi) = \sqrt{\frac{V_{tot}(\psi) - V_{min}}{V_{max} - V_{min}}}. \tag{3.17}$$

For 2-qubit case,  $V_{max}(\psi) = 6$  and  $V_{min}(\psi) = 4$  and it directly gives  $C(\psi) = 2|ad - bc|$  for pure states Eq.(3.14). In other words, both definitions of entanglement measures *Concurrence* and *Variational Principle* are equivalent for 2 qubit case.

### 3.1.3 single qutrit case

The single-photon entanglement is usually considered in terms of the two-qubit entanglement. One of qubits is intrinsic property of the photon like polarization, while the second qubit corresponds to the spatial degrees of freedom, defined by the two spatial modes of a single photon. These modes can be produced either by a beam splitter or through the use of two identical cavities, containing single excitation.

Consider now the case of a single qutrit (spin-1 particle), when the general state in the Hilbert space  $\mathbf{H}_1$  takes the form

$$|\psi(1)\rangle = \sum_{\ell=0}^2 \psi_{\ell} |\ell\rangle, \quad \sum_{\ell=0}^2 |\psi_{\ell}|^2 = 1. \tag{3.18}$$

The observables in this case correspond to the three-dimensional representation of the  $SL(2, \mathbf{C})$  algebra and have the form

$$\begin{cases} S_x &= \frac{1}{\sqrt{2}}(|0\rangle\langle 1| + |1\rangle\langle 2|) + H.c. \\ S_y &= \frac{-i}{\sqrt{2}}(|0\rangle\langle 1| + |1\rangle\langle 2|) + H.c. \\ S_z &= |0\rangle\langle 0| - |2\rangle\langle 2| \end{cases} \tag{3.19}$$

It is seen that

$$\hat{C} = S_x^2 + S_y^2 + S_z^2 = 2 \quad (3.20)$$

in this case. Thus, the condition Eq.(3.9), that can be applied instead of the condition Eq.(3.6), leads to the equations

$$\begin{cases} \operatorname{Re}(\psi_0\psi_1^*) + \operatorname{Re}(\psi_1\psi_2^*) & = 0 \\ \operatorname{Im}(\psi_0\psi_1^*) + \operatorname{Im}(\psi_1\psi_2^*) & = 0 \\ |\psi_0|^2 - |\psi_2|^2 & = 0 \end{cases}$$

which have infinitely many solutions described by the relations

$$\begin{cases} |\psi_2| & = |\psi_0| \\ 2|\psi_0|^2 + |\psi_1|^2 & = 1 \\ \arg \psi_0 - 2 \arg \psi_1 + \arg \psi_2 & = \pm\pi + 2k\pi \end{cases} \quad (3.21)$$

Thus, there are infinitely many ME states of a single qubit.

In particular, solutions (3.21) determine the following three ME states

$$\begin{cases} |1\rangle \\ \frac{1}{\sqrt{2}}(|0\rangle \pm |2\rangle) \end{cases} \quad (3.22)$$

forming a basis of ME states in the Hilbert space  $\mathbf{H}_1$  of a single qubit.

It should be noted that, unlike  $|1\rangle$ , the states  $|0\rangle$  and  $|2\rangle$  provide the minimal remoteness with the observables (3.19):

$$\mathbf{V}(|0\rangle) = \mathbf{V}(|2\rangle) = 1.$$

Hence, by definition, these states can be associated with the coherent states of a single qutrit.

To make the connection between single particle entanglement and well known two-qubits formalism let us consider first Clebsch-Gordon decomposition

$$\mathbf{H}_{\frac{1}{2}} \otimes \mathbf{H}_{\frac{1}{2}} = \mathbf{H}_1 \oplus \mathbf{H}_0, \quad (3.23)$$

of two spin- $\frac{1}{2}$  systems into symmetric component  $\mathbf{H}_1$  of spin 1, and skew symmetric scalar component  $\mathbf{H}_0$ . If we denote the base states in  $\mathbf{H}_{\frac{1}{2}}$  by  $|\uparrow\rangle$  and  $|\downarrow\rangle$ ,

then the basis of  $\mathbf{H}_1$  is represented by the symmetric triplet

$$\left\{ \begin{array}{l} |\uparrow\uparrow\rangle \\ |\downarrow\downarrow\rangle \\ \frac{1}{\sqrt{2}}(|\uparrow\downarrow\rangle + |\downarrow\uparrow\rangle) \end{array} \right. \quad (3.24)$$

while the antisymmetric singlet

$$\frac{1}{\sqrt{2}}(|\uparrow\downarrow\rangle - |\downarrow\uparrow\rangle) \quad (3.25)$$

corresponds to  $\mathbf{H}_0$ . Since the states of spin-1 system under consideration can always be specified by the projection of spin onto the quantization axis  $|m\rangle$ , the states (3.24) can be interpreted as the states  $|m = 1\rangle$ ,  $|m = -1\rangle$ , and  $|m = 0\rangle$ , respectively. From the physical point of view, this means that if a single spin-1 system, prepared initially in the state  $|m = 0\rangle$ , decays into the two spin- $\frac{1}{2}$  objects, they should be observed in the EPR (Einstein-Podolsky-Rosen) state (the last state in (3.24)). This is an indication that spin-1 state  $|m = 0\rangle$  is entangled. The other two states  $|m = \pm 1\rangle$  in the triplet (3.24) are coherent and decay into disentangled spin- $\frac{1}{2}$  components.

Taking into account that the general state of the spin-1 system

$$|\psi\rangle = \psi_{+1}|+1\rangle + \psi_{-1}|-1\rangle + \psi_0|0\rangle \quad (3.26)$$

can be formally represented in the form of the two-qubit state

$$|\psi\rangle = \psi_{\uparrow\uparrow}|\uparrow\uparrow\rangle + \psi_{\downarrow\downarrow}|\downarrow\downarrow\rangle + \psi_{\uparrow\downarrow}(|\uparrow\downarrow\rangle + |\downarrow\uparrow\rangle)$$

in the symmetric sector, and that the *concurrence* (measure of entanglement in the case of two qubits) has the form

$$\mathbf{C}(\psi) = 2|\det[\psi]| = 2|\psi_{\uparrow\uparrow}\psi_{\downarrow\downarrow} - \psi_{\uparrow\downarrow}\psi_{\downarrow\uparrow}|,$$

we can conclude that the amount of entanglement in state (3.26) can be measured by the expression [41]

$$\mathbf{C}(\psi) = 2|\psi_{+1}\psi_{-1} - \psi_0^2/2|, \quad (3.27)$$

which represents the concurrence in the case of spin-1 system. It is interesting that the concurrence can also be expressed in terms of the total amount of fluctuations as follows

$$\mathbf{C}(\psi) = \sqrt{\frac{V_{tot}(\psi) - V_{min}}{V_{max} - V_{min}}}.$$

Concerning physical realizations, let us mention first that the three-dimensional entanglement in orbital angular momentum of photons provides an example, illustrating the above theory. Namely, a single photon in Laguerre-Gauss beam in the state  $|m = 0\rangle$  is entangled by itself. Let us stress that in the usual treatment, entanglement with respect to the orbital angular momentum of a pair of photons is discussed.

According to these results, a single dipole photon with angular momentum  $j = 1$  and projection  $m = 0$  is always in the ME state. In view of the above interpretation, we can assume that such a photon may decay into a pair of entangled particles. In other words, the electron-positron pair created by the photodecay of the dipole photon with  $m = 0$  should be prepared in the ME EPR state (the last state in (3.24)) with respect to the spin of charged particles. This may be observed in the presence of a strong electric field, which separates the particles with opposite charge and, unlike the magnetic field, does not influence the spin state. Other photon decay processes such as resonance down-conversion and Raman scattering with creation of the entangled pairs can also be described using the above formalism.

Another example of single-particle ME state is provided by the isodoublet of quarks with only two flavors, namely up- and down-quarks, forming  $\pi$ -mesons. The  $\pi^\pm$ -mesons represent the coherent states with respect to the quarks

$$\pi^+ = u\bar{d}, \quad \pi^- = \bar{u}d.$$

In contrast,  $\pi^0$ -meson is prepared in the ME state of the type of  $|\psi_0\rangle$  in (3.22)

$$\pi^0 = \frac{u\bar{u} - d\bar{d}}{\sqrt{2}}.$$

Since ME corresponds to the maximum of the total amount of fluctuations, all

one can expect is that  $\pi^0$  meson should be less stable than  $\pi^\pm$ . In fact, the experimental ratio of the lifetimes is  $\tau_0/\tau_\pm \sim 10^{-9}$ .

ME states of other qudits (particles with "spin"  $(d-1)/2$ ) can be considered in the same way.

## 3.2 Maximum Principle and $SU(2)$ Phase States for Qubits

In this part, I will show that the  $SU(2)$  phase states of spin  $j$  defined as

$$j = \frac{1}{2} \left[ \binom{2n}{n} - 1 \right] \quad (3.28)$$

in a  $2n+n$ -type atom-photon system obey the non-separability conditions, have the maximum principle explained in the previous section, and manifest the violation of classical realism expressed in terms of the Greenberger-Horne-Zeilinger (GHZ) [33] and Clauser-Horne-Shimony-Holt (CHSH) [42] conditions.

For this aim, I will consider the representation of the  $SU(2)$  phase states. As a particular example, I examine the system of two identical two-level atoms, interacting with a single cavity photon and show that the maximum entangled atomic states of the Ref. [4] belong to the class of the  $SU(2)$  phase states of spin  $j = 1/2$ . Let me stress that hereafter the maximum entanglement is defined in the usual way by the maximum of reduced entropy (e.g., see Refs. [35, 43, 28, 34]). Then, I generalize this result on the case of  $2n+n$  system. As a nontrivial example I consider the system of four identical two-level atoms interacting with the two cavity photons. In this case, the set of entangled, maximum excited atomic states is provided by the six orthogonal  $SU(2)$  phase states of spin  $j = 5/2$ . For these states, violation of classical realism is proved through the use of GHZ and CHSH conditions. After that, I discuss how the entangled atomic states can be achieved in the process of steady-state evolution. In particular, I show that the maximum entanglement can be achieved if the initial state of the system contains

the photons and does not contain the atomic excitations. I also show that the presence of the cavity detuning hampers the creation of pure entangled states and that the parasitic influence of detuning can be compensated through the use of the Kerr medium inside the cavity.

### 3.2.1 Entanglement of 2-level atoms

Variational principle can be illustrated by the atoms-plus-photons systems. Consider first the set of two identical two-level atoms. Let  $|e_\ell\rangle$  and  $|g_\ell\rangle$  denote the excited and ground atomic states of the  $\ell^{\text{th}}$  atom, respectively. Then, the entangled, maximum excited atomic states in the system "2 atoms plus 1 photon" considered in Ref.[4] are

$$|\psi_\pm\rangle = \frac{1}{\sqrt{2}}(|e_1g_2\rangle \pm |g_1e_2\rangle). \quad (3.29)$$

Then, the local measurement  $g$  can be described by the Pauli matrices

$$\begin{aligned} \sigma_1^{(\ell)} &= |e_\ell\rangle\langle g_\ell| + |g_\ell\rangle\langle e_\ell|, \\ \sigma_2^{(\ell)} &= -i|e_\ell\rangle\langle g_\ell| + i|g_\ell\rangle\langle e_\ell|, \\ \sigma_3^{(\ell)} &= |e_\ell\rangle\langle e_\ell| - |g_\ell\rangle\langle g_\ell|, \end{aligned} \quad (3.30)$$

i.e., by the infinitesimal generators of the algebra  $SL(2, C)$ . It is now a straightforward matter to check that

$$\forall i, \ell \quad \langle \psi_\pm | \sigma_i^{(\ell)} | \psi_\pm \rangle = 0, \quad (3.31)$$

where averaging is taken over the states Eq.(3.29). Another example is provided by the GHZ states Ref.[33]

$$|\psi_\pm^{(GHZ)}\rangle = \frac{1}{\sqrt{2}}(|e_1e_2e_3\rangle \pm |g_1g_2g_3\rangle), \quad (3.32)$$

corresponding to the maximum atomic excitation in the 3+3-system. It is easily seen that the averaging of the local operators Eq.(3.30) over Eq.(3.32) gives the same result as Eq.(3.31).



### 3.2.2 Representation of the $SU(2)$ phase states

$SU(2)$  is isomorphic to the  $SO(3)$  which describes the rotations in three dimensional space. The Pauli matrices (3.12) are the lowest dimensional realizations of infinitesimal rotations in this three dimensional space.

Moreover they are the generators of the  $SU(2)$  algebra.

The  $SU(2)$  phase states were introduced in Ref.[44] for an arbitrary spin and then generalized in Ref.[45, 46] to the case of the  $SU(2)$  subalgebra in the Weyl-Heisenberg algebra of photon operators (for recent review, see Ref.[47]).

An arbitrary spin  $j$  can be described by the generators  $J_+, J_-, J_z$  of the  $SU(2)$  algebra such that

$$\begin{aligned} [J_+, J_-] &= 2J_z, & [J_z, J_\pm] &= \pm J_\pm, \\ J^2 &= J_z^2 + \frac{1}{2}(J_+J_- + J_-J_+) = j(j+1) \times \mathbf{1}, \end{aligned} \quad (3.33)$$

where  $\mathbf{1}$  is the unit operator in the  $2j+1$  dimensional Hilbert space. Since

$$J_\pm = J_x \pm iJ_y,$$

it is possible to say that the generators  $J_+, J_-, J_z$  in Eq(3.33) correspond to the Cartesian representation of the  $SU(2)$  algebra. Following Ref.[44], one can introduce the representation in spherical coordinates via the polar decomposition of Eq(3.33) of the form

$$J_+ = J_r \epsilon, \quad J_- = J_r^+, \quad \epsilon \epsilon^+ = \mathbf{1}, \quad (3.34)$$

where the Hermitian operator  $J_r$  corresponds to the radial contribution, while  $\epsilon$  gives the exponential of the azimuthal phase operator. It is a straightforward matter to show that  $\epsilon$  can be represented by the following  $(2j+1) \times (2j+1)$  matrix

$$\epsilon = \begin{pmatrix} 0 & 1 & 0 & 0 & \cdots & 0 \\ 0 & 0 & 1 & 0 & \cdots & 0 \\ \vdots & \vdots & \vdots & \vdots & \vdots & \vdots \\ 0 & 0 & 0 & 0 & \cdots & 1 \\ e^{i\psi} & 0 & 0 & 0 & \cdots & 0 \end{pmatrix} \quad (3.35)$$

in the  $2j + 1$ -dimensional Hilbert space. Here  $\psi$  is an arbitrary real parameter (reference phase). The eigenstates of the operator Eq(3.35)

$$\epsilon|\phi_n^{(j)}\rangle = e^{i\phi_n^{(j)}}|\phi_n^{(j)}\rangle, \quad n = 1, \dots, (2j + 1), \quad (3.36)$$

form the basis of the so-called phase states

$$|\psi_n^{(j)}\rangle = \frac{1}{\sqrt{2j+1}} \sum_{k=0}^{2j} e^{ik\phi_n^{(j)}} |\psi_k\rangle \quad (3.37)$$

dual with respect to the basis of individual states  $|\psi_k\rangle$  of the Hilbert space.

As a physical example of some considerable interest, consider now the system of the two identical two-level atom interacting with the single cavity photon (see Ref.[4]). If the cavity photon is absorbed by either atom, the atomic subsystem can be observed in the following states

$$|\psi_1\rangle = |e_1g_2\rangle, \quad |\psi_2\rangle = |g_1e_2\rangle, \quad (3.38)$$

where  $|e_1g_2\rangle = |e_1\rangle \otimes |g_2\rangle$  and  $|e\rangle$  and  $|g\rangle$  denote the excited and ground atomic states, respectively. The subscript marks the atom. Using the atomic basis Eq(3.38), we can construct the following representation of the  $SU(2)$  algebra:

$$\begin{aligned} J_+ &= |e_1g_2\rangle\langle g_1e_2|, \quad J_- = |g_1e_2\rangle\langle e_1g_2|, \\ J_3 &= \frac{1}{2}(|e_1g_2\rangle\langle e_1g_2| - |g_1e_2\rangle\langle g_1e_2|). \end{aligned} \quad (3.39)$$

This representation formally corresponds to Eq(3.33) at the spin  $j = 1/2$ . Then, the corresponding exponential of the phase operator Eq(3.35) takes the form

$$\epsilon = |e_1g_2\rangle\langle g_1e_2| + e^{i\psi}|g_1e_2\rangle\langle e_1g_2|. \quad (3.40)$$

In turn, the phase states Eq(3.36) and Eq(3.37) are

$$\begin{aligned} |\phi_{\pm}\rangle &= \frac{1}{\sqrt{2}}(|e_1g_2\rangle + e^{i\phi_{\pm}}|g_1e_2\rangle), \\ \phi_{\pm} &= \psi/2 + (1 \mp 1)\pi/2. \end{aligned} \quad (3.41)$$

It is easily seen that the phase states Eq(3.41) form the set of entangled atomic states in the two-atom system under consideration. Definitely, these states obey

the nonseparability condition. It is also seen that Eq(3.41) coincides with the maximally entangled states Eq(3.29) of Ref. [4] when the reference phase  $\psi = 0$ .

Consider now a general  $2n + n$  system at  $n \geq 1$ . Then, the maximum excited atomic states

$$|\psi_i\rangle = |\{e\}_n, \{g\}_n\rangle, \quad (3.42)$$

can be used to construct a representation of the  $SU(2)$  algebra Eq(3.33) of spin  $j$  defined in (1). Here  $i = 1, 2, \dots, N$  and

$$N = 2j + 1 = \binom{2n}{n}$$

is the total number of such a states. In the basis Eq(3.42), we can construct the polar decomposition of the  $SU(2)$  algebra of spin Eq(3.28) and the corresponding exponential of the phase operator Eq(3.35) and the phase states Eq(3.37). Let us rename the states Eq(3.42) as follows

$$|\psi_k\rangle \rightarrow |\psi_{k'}\rangle, \quad k' \equiv k - 1 = 0, \dots, N - 1.$$

Then, the  $SU(2)$  phase states Eq(3.37) take the form

$$|\phi_k\rangle = \frac{1}{\sqrt{N}} \sum_{k'=0}^{N-1} e^{ik'\phi_k} |\psi_{k'}\rangle, \quad (3.43)$$

where

$$\phi_k = (\psi + 2k\pi)/N.$$

These states Eq(3.43) form a basis dual with respect to Eq(3.42) and spanning the Hilbert space of the maximum excited atomic states in the  $2n + n$  system under consideration. By construction, the phase states Eq(3.43) are nonseparable with respect to contributions of individual atoms and thus entangled [48]. Let us stress that the choice of the phase factors in Eq(3.43) is irrelevant to entanglement, which holds for arbitrary phase factors. This choice is caused by the aspiration for getting the dual with respect to Eq(3.42) basis of entangled states.

It is easily seen that the states Eq(3.43) obey the maximum condition Eq(3.31). In fact, the action of the flip-operators  $\sigma_{1,2}^{(\ell)}$  in Eq(3.30) on the states

Eq(3.43) leads to the change of the number of either excited or de-excited atoms:

$$\sigma_{1,2}^{(\ell)}|\psi_k\rangle \rightarrow \begin{cases} |\{e\}_{n-1}, \{g\}_{n+1}\rangle & \ell \in \{g\} \\ |\{e\}_{n+1}, \{g\}_{n-1}\rangle & \ell \in \{e\} \end{cases}$$

and therefore  $\langle\sigma_{1,2}^{(\ell)}\rangle = 0$  in the case of averaging over the states Eq(3.43). Since each state Eq(3.42) contains equal number of excited and de-excited atoms, the action of the parity operator in Eq(3.30) on the phase states Eq(3.43) should lead to the state which differ from Eq(3.43) by the multiplication of a certain  $n$  terms by the factor of  $-1$ . Hence

$$\langle\sigma_3^{(\ell)}\rangle = \frac{1}{N} \left( \sum_{i=1}^{N/2} 1 - \sum_{i=N/2+1}^N 1 \right) = 0.$$

By construction,  $N$  is always an even number. Thus, the  $SU(2)$  phase states Eq(3.43), corresponding to the maximum excited atomic states in the  $2n + n$  system, are entangled because they are nonseparable and, at the same time, obey the condition Eq(3.31) for the local measurements. In the next Section, we show that the states Eq(3.43) manifest violation of classical realism as well.

Before we begin to discuss this subject, let us note that the  $SU(2)$  phase states of the atomic system under consideration with integer spin do not provide the entanglement. Consider as an example the system of three identical two-level atoms, interacting with a single cavity photon. There are the three excited atomic states

$$|e_1g_2g_3\rangle, \quad |g_1e_2g_3\rangle, \quad |g_1g_2e_3\rangle \quad (3.44)$$

and the three dual phase states of the type of Eq(3.43)

$$|\psi_k\rangle = \frac{1}{\sqrt{3}}(|e_1g_2g_3\rangle + e^{i\phi_k}|g_1e_2g_3\rangle + e^{2i\phi_k}|g_1g_2e_3\rangle). \quad (3.45)$$

It is clear that the states Eq(3.45) are the phase states of spin  $j = 1$ . Here

$$\phi_k = (\psi + 2k\pi)/3, \quad k = 0, 1, 2.$$

It is easily seen that the phase states Eq(3.45) cannot be factorized with respect to atoms. At the same time, the average of the parity operator  $\sigma_3^{(\ell)}$  in Eq(3.30)

over the states Eq(3.45) is

$$\forall k, \ell \quad \langle \psi_k | \sigma_3^{(\ell)} | \psi_k \rangle = -\frac{1}{3},$$

although the averages of the flip-operators are

$$\forall k, \ell \quad \langle \psi_k | \sigma_{1,2}^{(\ell)} | \psi_k \rangle = 0.$$

Thus, the nonseparable states Eq(3.45) do not obey the condition Eq(3.31). At the same time, these states do not manifest the maximum entanglement as well. Let us stress that the nonseparability is not a sufficient condition of maximum entanglement Ref.[48]. For example, from the measurement of the state of the first atom we can only learn that either the atoms 2 and 3 are both in the ground state with reliability or they are in the two-atom entangled state of the type discussed in Ref.[4]. Similar result can be obtained for the system of three atoms, interacting with two cavity photons. The only maximum entangled state of the system of three atoms is provided by the superposition of GHZ states Eq.(3.32).

### 3.2.3 An example

Here 4+2 system i.e. four two level atoms with two photons will be considered. To show that the phase states Eq(3.43) of a  $2n + n$  system violate the classical realism, consider the system of four identical two-level atoms interacting with two cavity photons. The maximum excited atomic states at  $n = 2$  are

$$\begin{aligned} & |e_1 e_2 g_3 g_4\rangle, \quad |e_1 g_2 e_3 g_4\rangle, \quad |e_1 g_2 g_3 e_4\rangle, \\ & |g_1 e_2 e_3 g_4\rangle, \quad |g_1 e_2 g_3 e_4\rangle, \quad |g_1 g_2 e_3 e_4\rangle. \end{aligned} \quad (3.46)$$

These orthonormal states form the six-dimensional basis of the Hilbert space in which the representation of the generators Eq(3.33) has the form

$$\begin{aligned} J_+ &= \sqrt{5} |e_1 e_2 g_3 g_4\rangle \langle e_1 g_2 e_3 g_4| + \sqrt{8} |e_1 g_2 e_3 g_4\rangle \langle e_1 g_2 g_3 e_4| \\ &+ 3 |e_1 g_2 g_3 e_4\rangle \langle g_1 e_2 e_3 g_4| + \sqrt{8} |g_1 e_2 e_3 g_4\rangle \langle g_1 e_2 g_3 e_4| \\ &+ \sqrt{5} |g_1 e_2 g_3 e_4\rangle \langle g_1 g_2 e_3 e_4|, \\ J_3 &= \frac{5}{2} |e_1 e_2 g_3 g_4\rangle \langle e_1 e_2 g_3 g_4| + \frac{3}{2} |e_1 g_2 e_3 g_4\rangle \langle e_1 g_2 e_3 g_4| \end{aligned}$$

$$\begin{aligned}
& + \frac{1}{2}|e_1g_2g_3e_4\rangle\langle e_1g_2g_3e_4| - \frac{1}{2}|g_1e_2e_3g_4\rangle\langle g_1e_2e_3g_4| \\
& - \frac{3}{2}|g_1e_2g_3e_4\rangle\langle g_1e_2g_3e_4| - \frac{5}{2}|g_1g_2e_3e_4\rangle\langle g_1g_2e_3e_4|
\end{aligned}$$

By construction, they describe the spin  $j = 5/2$  system. In turn, the exponential of the phase operator Eq(3.35) takes the form

$$\begin{aligned}
\epsilon & = |e_1e_2g_3g_4\rangle\langle e_1g_2e_3g_4| + |e_1g_2e_3g_4\rangle\langle e_1g_2g_3e_4| \\
& + |e_1g_2g_3e_4\rangle\langle g_1e_2e_3g_4| + |g_1e_2e_3g_4\rangle\langle g_1e_2g_3e_4| \\
& + |g_1e_2g_3e_4\rangle\langle g_1g_2e_3e_4| + e^{i\psi}|g_1g_2e_3e_4\rangle\langle e_1e_2g_3g_4|.
\end{aligned}$$

Then, the six phase states Eq(3.36) have the form Eq(3.43) with  $N = 6$  and

$$\phi_k = \frac{\psi}{6} + \frac{k\pi}{3}, \quad k = 0, 1, \dots, 5. \quad (3.47)$$

As well as Eq(3.43), these states are nonseparable and hence entangled and obey the condition Eq(3.31) for local variables.

To show that these phase states violate the classical realism, let us first represent the states Eq(3.43) at  $N = 6$  in the following way

$$|\phi_k\rangle = \frac{1}{\sqrt{3}}(|\chi_{1k}\rangle + e^{i\phi_k}|\chi_{2k}\rangle + e^{2i\phi_k}|\chi_{3k}\rangle), \quad (3.48)$$

where

$$\begin{aligned}
|\chi_{1k}\rangle & = \frac{1}{\sqrt{2}}(|e_1e_2g_3g_4\rangle + e^{5i\phi_k}|g_1g_2e_3e_4\rangle), \\
|\chi_{2k}\rangle & = \frac{1}{\sqrt{2}}(|g_1e_2e_3g_4\rangle + e^{3i\phi_k}|e_1g_2g_3e_4\rangle), \\
|\chi_{3k}\rangle & = \frac{1}{\sqrt{2}}(|g_1e_2g_3e_4\rangle + e^{i\phi_k}|e_1g_2e_3g_4\rangle).
\end{aligned} \quad (3.49)$$

It is easily seen that each set of six states  $|\chi_{pk}\rangle$  with  $p = 1, 2, 3$  and  $k = 0, \dots, 5$  consists of the nonseparable and hence entangled states. Consider, for example, the states  $|\chi_{1k}\rangle$  in Eq(3.49). Because of the definition of the phase angle  $\phi_k$  at  $N = 6$ , they consist of the three sets of the pairwise orthogonal states

$$\{|\chi_{10}\rangle, |\chi_{13}\rangle\}, \quad \{|\chi_{11}\rangle, |\chi_{14}\rangle\}, \quad \{|\chi_{12}\rangle, |\chi_{15}\rangle\}.$$

It is also seen that the second and third sets here are obtained from the first set by the successive rotations of the reference frame.

Now the violation of classical realism can be proved through the use of the GHZ theorem Ref.[33]. Consider first the state  $|\chi_{10}\rangle$  in Eq(3.49). It is easy to verify that this state obey the conditions

$$\forall i, \ell \quad \bigotimes_{\ell=1}^4 \sigma_i^{(\ell)} |\chi_{10}\rangle = |\chi_{10}\rangle \quad (3.50)$$

and

$$\begin{aligned} \sigma_1^{(1)} \sigma_1^{(2)} \sigma_2^{(3)} \sigma_2^{(4)} |\chi_{10}\rangle &= -|\chi_{10}\rangle, \\ \sigma_2^{(1)} \sigma_2^{(2)} \sigma_1^{(3)} \sigma_1^{(4)} |\chi_{10}\rangle &= -|\chi_{10}\rangle, \\ \sigma_1^{(1)} \sigma_2^{(2)} \sigma_1^{(3)} \sigma_2^{(4)} |\chi_{10}\rangle &= |\chi_{10}\rangle, \\ \sigma_1^{(1)} \sigma_2^{(2)} \sigma_2^{(3)} \sigma_1^{(4)} |\chi_{10}\rangle &= |\chi_{10}\rangle, \\ \sigma_2^{(1)} \sigma_1^{(2)} \sigma_2^{(3)} \sigma_1^{(4)} |\chi_{10}\rangle &= |\chi_{10}\rangle, \\ \sigma_2^{(1)} \sigma_1^{(2)} \sigma_1^{(3)} \sigma_2^{(4)} |\chi_{10}\rangle &= |\chi_{10}\rangle. \end{aligned} \quad (3.51)$$

It is possible to say that these equalities Eq(3.50) and Eq(3.51) express a kind of EPR "action at distance" in the maximum excited states of the system of four atoms interacting with two photons. In other words, the correlations represented by Eq(3.50) and Eq(3.51) permit us determine in a unique way the state of the fourth atom via measurement of the states of other three atoms.

The operator equalities Eq(3.50) and Eq(3.51) can be used to obtain the relations similar to those in the GHZ theorem. Following Ref.[33], we have to assign the classical quantities  $m_i^{(\ell)}$  to the local operators. Here

$$m_1^{(\ell)}, m_2^{(\ell)} = \pm 1.$$

Then, it follows from Eq(3.50) that

$$\prod_{\ell=1}^4 m_1^{(\ell)} = 1. \quad (3.52)$$

At the same time, it follows from Eq(3.51) that

$$[\sigma_1^{(1)} \sigma_1^{(2)} \sigma_2^{(3)} \sigma_2^{(4)}][\sigma_1^{(1)} \sigma_2^{(2)} \sigma_1^{(3)} \sigma_2^{(4)}][\sigma_1^{(1)} \sigma_2^{(2)} \sigma_2^{(3)} \sigma_1^{(4)}] |\chi_{10}\rangle = -|\chi_{10}\rangle.$$

Employing the classical variables instead of the local operators allows this to be cast into the form

$$(m_1^{(1)})^3 m_1^{(2)} (m_2^{(2)})^2 m_1^{(3)} (m_2^{(3)})^2 m_1^{(4)} (m_2^{(4)})^2 = -1.$$

Since  $(m_1^{(\ell)})^2 = (m_2^{(\ell)})^2 = 1$ , we get an equivalent equality

$$m_1^{(1)} m_1^{(2)} m_1^{(3)} m_1^{(4)} = -1,$$

which contradicts Eq(3.52). Hence, the state  $|\chi_{10}\rangle$  in Eq(3.49) obey the GHZ theorem. Similar result can be obtained for all other states in Eq(3.49) and hence, for the phase states Eq(3.48).

Our consideration so far have applied to the local measurements touching on a single atom. We now note that the phase states Eq(3.48) allow another kind of entanglement in the case of pairwise measurement. Consider again the state  $|\chi_{10}\rangle$  in Eq(3.49) and assume that the measurements  $a$  and  $b$  corresponds to a pair of atoms:

$$\begin{aligned} a &= \cos \theta_a |e_1 e_2\rangle \langle e_1 e_2| + \sin \theta_a (|e_1 e_2\rangle \langle g_1 g_2| \\ &\quad + |g_1 g_2\rangle \langle e_1 e_2|) - \cos \theta_a |g_1 g_2\rangle \langle g_1 g_2|, \\ b &= \cos \theta_b |e_3 e_4\rangle \langle e_3 e_4| + \sin \theta_b (|e_3 e_4\rangle \langle g_3 g_4| \\ &\quad + |g_3 g_4\rangle \langle e_3 e_4|) - \cos \theta_b |g_3 g_4\rangle \langle g_3 g_4|. \end{aligned} \quad (3.53)$$

Assume now that we make the two measurements  $a$  and  $a'$  with the angles  $\theta_a = \pi$  and  $\theta'_a = \pi/2$  and the two more measurements  $b$  and  $b'$  with the angles  $\theta'_b = -\theta_b$ , respectively. Then, the averaging over the state  $|\chi_{10}\rangle$  gives

$$\langle ab \rangle = \langle ab' \rangle = \cos \theta_b, \quad \langle a'b \rangle = \sin \theta_b = -\langle a'b' \rangle.$$

Employing the CHSH inequality Ref.[42]

$$|\langle ab \rangle + \langle a'b \rangle + \langle a'b' \rangle - \langle ab' \rangle| \leq 2 \quad (3.54)$$

then gives

$$|\cos \theta_b - \sin \theta_b| \leq 1.$$

Violation of this inequality and hence, of the classical realism occurs at small negative  $\theta_b$ , when we can put

$$|\cos \theta_b - \sin \theta_b| \sim 1 + |\theta_b| > 1.$$



Similar consideration can be done for all over states in Eq(3.49) through the use of proper pairwise measurements. At the same time, the phase states Eq(3.48) do not manifest entanglement with respect to the pairwise measurements.

The phase states Eq(3.43) for the  $6 + 3$ ,  $8 + 4$ ,  $\dots$  systems, corresponding to the spin Eq(3.28) equal to  $19/2, 69/2, \dots$ , respectively, can be considered as above.

### 3.2.4 Effect of Initial Conditions on Atomic Entanglement

It is clear that the evolution of the  $2n+n$  system strongly depends on the choice of initial conditions. To trace the proper choice leading to the atomic entanglement, let us ignore the relaxation processes. Then, the steady-state evolution of the  $2n + n$  system under consideration is governed by the Hamiltonian

$$H = \Delta a^+ a + \omega_0 \mathcal{N} + \gamma \sum_{\ell} (R_{\ell}^+ a + a^+ R_{\ell}). \quad (3.55)$$

Here  $\Delta$  is the cavity detuning,  $\omega_0$  is the atomic transition frequency,  $\gamma$  is the atom-field coupling constant, operators  $a$  and  $a^+$  describe the cavity photons,

$$\mathcal{N} = a^+ a + \sum_{\ell} |e_{\ell}\rangle \langle e_{\ell}| \bigotimes_{\ell' \neq \ell} \mathbf{1}^{(\ell')},$$

and the atomic operators are defined as follows

$$R_{\ell}^{\pm} = |e_{\ell}\rangle \langle g_{\ell}| \bigotimes_{\ell' \neq \ell} \mathbf{1}^{(\ell')}.$$

Here  $\mathbf{1}^{(\ell)}$  denotes the unit operator in the two-dimensional Hilbert space of the  $\ell^{th}$  atom. It is seen that  $[\mathcal{N}, H] = 0$ . It is also seen that the atomic operators are similar, in a certain sense, to the local operators Eq(3.30). In fact

$$R_{\ell}^{\pm} = \frac{\sigma_1^{(\ell)} \pm i\sigma_2^{(\ell)}}{2}.$$

Consider first the case of two atoms and single cavity photon when  $\ell = 1, 2$  and the Hamiltonian Eq(3.55) coincides with that of Ref.[4]. For simplicity, we use

here the same coupling constant  $\gamma$  for both atoms. Our consideration can easily be generalized on the case of coupling constant depending on the atomic position. Let us note that, in the case of only two atoms, the Hamiltonian Eq(3.55) can be represented as follows

$$H \rightarrow H_\phi = \Delta a^\dagger a + \omega_0 \mathcal{N}_\phi + \gamma\sqrt{2}(\mathcal{R}^+ a + a^\dagger \mathcal{R}), \quad (3.56)$$

where

$$\mathcal{N}_\phi = a^\dagger a + \sum_{k=\pm 1} |\phi_k\rangle\langle\phi_k|$$

and

$$\mathcal{R}^+ = |\phi_+\rangle\langle g_1 g_2|.$$

Here  $|\phi_\pm\rangle$  denote the phase states Eq(3.41).

Using the Hamiltonian Eq(3.56) as the generator of evolution, for the time dependent wave function we get

$$\begin{aligned} |\Psi(t)\rangle &= e^{-iH_\phi t} |\Psi(0)\rangle \\ &= [C_-(t)|\phi_-\rangle + C_+(t)|\phi_+\rangle] \otimes |0\rangle_{ph} + C(t)|g_1 g_2\rangle \otimes |1\rangle_{ph}, \end{aligned} \quad (3.57)$$

where  $|\dots\rangle_{ph}$  denotes the states of the cavity field. The coefficients  $C_\pm(t)$  and  $C(t)$  in Eq(3.57) are completely determined by the initial conditions and normalization condition.

It is easily seen that the state  $|\phi_-\rangle \otimes |0\rangle_{ph}$  is the eigenstate of the Hamiltonian Eq(3.56). Hence, at

$$C_-(0) = 1, \quad C_+(0) = C(0) = 0,$$

the atomic phase state  $|\phi_-\rangle$  in Eq(3.41) provides the stationary, maximum entangled atomic state in the system under consideration Ref.[4]. At the same time, it is not very clear how to prepare such a state.

Therefore we consider a more realistic initial state provided by excitation of either atom, while the cavity field is in the vacuum state. To realize such a state,

we can assume, for example, that one of the atoms (initially de-excited) is trapped in the cavity, while the second atom (initially excited) slowly passes through the cavity like in the experiments discussed in Ref.[49, 50]. assume for definiteness that

$$|\Psi(0)\rangle = |e_1g_2\rangle \otimes |0\rangle_{ph}. \quad (3.58)$$

Then, the coefficients of the wave function Eq(3.57) take the form

$$\begin{aligned} C_-(t) &= \frac{1}{\sqrt{2}}e^{-i\omega_0 t}, \\ C_+(t) &= \frac{1}{\sqrt{2}}\left(\cos \Omega t + \frac{i\Delta}{2\Omega} \sin \Omega t\right) e^{-i(\omega_0+\Delta/2)t}, \\ C(t) &= -\frac{i\gamma}{\Omega}e^{-i(\omega_0+\Delta/2)t} \sin \Omega t, \end{aligned}$$

where  $\Omega = [2\gamma^2 + (\Delta/2)^2]^{1/2}$ . At first site, the probabilities

$$P_{\pm}(t) = |\langle 0|_{ph} \otimes \langle \phi_{pm}|\Psi(t)\rangle|^2 = |C_{\pm}(t)|^2$$

to observe the states Eq(3.41) corresponding to the maximum atomic entanglement, are

$$\begin{aligned} P_-(t) &= \frac{1}{2}, \\ P_+(t) &= \frac{\Delta^2}{8\Omega^2} + \frac{\gamma^2}{\Omega^2} \cos^2 \Omega t \leq \frac{1}{2}, \end{aligned}$$

respectively. At the same time, the absence of photon counts, which is considered in Ref.[4] as a sign of the atomic entanglement, corresponds here to the case when both probabilities  $P_{\pm}(t_k) = 1/2$  at a certain time  $t_k$ . In other words, the mutually orthogonal entangled states Eq(3.41) have the same probability to be observed at  $t = t_k$ . This means that there is no atomic entanglement at all but we definitely know which atom is in the excited state.

Consider one more realistic initial state when both atoms are trapped in the cavity in de-excited state, while the cavity field contains a photon:

$$|\Psi(0)\rangle = |g_1g_2\rangle \otimes |1\rangle_{ph}. \quad (3.59)$$

Then, for all times we get  $C_-(t) = 0$  and

$$\begin{aligned} C_+(t) &= -\frac{i\gamma\sqrt{2}}{\Omega}e^{-i(\omega_0+\Delta/2)t}\sin\Omega t, \\ C(t) &= \left(\cos\Omega t - \frac{i\Delta}{2\Omega}\sin\Omega t\right)e^{-i(\omega_0+\Delta/2)t}. \end{aligned}$$

Hence, under this initial condition, the entangled state  $|\phi_-\rangle$  cannot be achieved at all, while the second entangled state  $|\phi_+\rangle$  in Eq(3.41) can be achieved. It is seen that, in the case of initial state Eq(3.59), the probability to detect the photon is

$$P_{ph}(t) = |C(t)|^2 = \cos^2\Omega t + \frac{\Delta^2}{4\Omega^2}\sin^2\Omega t.$$

This expression takes the minimum value

$$\min P_{ph} = P_{ph}(t_m) = \frac{\Delta^2}{4\Omega^2}$$

at  $t = t_m = \pi(2m + 1)/2\Omega$ ,  $m = 0, 1, \dots$ . At the same time  $t_m$ , the probability to have the entangled atomic state  $|\phi_+\rangle$  takes the maximum value

$$P_+(t_m) = |C_+(t_m)|^2 = \frac{2\gamma^2}{2\gamma^2 + (\Delta/2)^2}.$$

It is seen that the pure atomic entanglement with  $P_+(t_m) = 1$  is realized at  $t = t_m$  only in the absence of the cavity detuning when  $\Delta \rightarrow 0$ .

The parasitic influence of the cavity detuning can be compensated through the use of Kerr medium filling the cavity. In this case, the Hamiltonian Eq(3.55) should be supplemented by the term

$$H_\kappa = \kappa(a^\dagger a)^2,$$

which leads to the following renormalization of the Rabi frequency

$$\Omega \rightarrow \Omega_\kappa = \sqrt{2\gamma^2 + (\Delta + \kappa)^2/4}.$$

Then, the proper choice of the Kerr parameter  $\kappa = -\Delta$  should lead to the pure entangled atomic state  $|\phi_+\rangle$  at a certain times.

Consider now the case of four atoms and two photons. In contrast to the previous case, neither phase state in Eq(3.48) is an eigenstate of the Hamiltonian

Eq(3.55). Then, the choice of the initial state either as a state with two excited atoms or as a state with one excited atom plus cavity photon does not lead to a pure atomic entanglement. As in the case of two atoms, the pure atomic entanglement can be reached under the choice of the state with the absence of the atomic excitations in the initial state. The influence of the cavity detuning can be compensated by the presence of Kerr medium as well as in the case of two atoms.

### 3.3 Summary

In this chapter we have explained a new variational principle defining the maximally entangled states from operational point of view or what can be measured. Next we have applied this principle for a single qubit, 2 qubit and a single qutrit. We have showed that although it doesn't lead to single entanglement for two level system, it is possible to obtain a single three level entangled state. Finally in the last section of the chapter using  $SU(2)$  phase states we have generalized N-two level entangled atomic states.

## Chapter 4

# Mini-max Principle for Robust Entanglement

In the previous chapter, we have discussed a new principle which defines the maximally entangled states. To produce maximally entangled state is not enough for practical application since they are very sensitive to environmental effects, these states can easily be disappear. Therefore it is also necessary to produce robust or stable entangled states. In this chapter, we will discuss how to make them robust that is immune to specific environmental effects such as decoherence and spontaneous emission.

In the first part of this chapter, the requirements to obtain persistent entangled states are explained. In other words maximum principle of the previous chapter for definition of maximally entangled states and minimum principle for robustness are combined to a key principle *Mini-max principle* which is necessary and practical for different applications in quantum information processing and quantum computing.

## 4.1 Mini-max Principle

Quantum information technologies desires high amount of entanglement and long life time. For atomic systems which are one of the main models for realizations of qubits, lifetime of maximally entangled states is usually governed by spontaneous decay time of the excited atomic levels, which is quite short.

In order to obtain practically applicable states we have to achieve some requirements for candidate physical system

- the highest level of quantum fluctuations,
- the minimum or at least local minimum of energy.

In other words, the state of the system  $S$  with maximum amount of quantum fluctuations should be prepared then the energy of the system should be decreased up to a local minimum under the condition of conservation of the level of quantum fluctuations. This is called *Mini-max principle*.

Time evolution of a physical system is governed by the Hamiltonian which is hermitian and expectation value of this Hamiltonian gives the amount of energy in the system at a given time. If the quantum system is well separated from its environments this leads to the conservation of energy and the time evolution is unitary. That is it is reversible in time. However in most cases and all of the realistic situations quantum systems are open to the environmental effects. In a sense they are a part of a bigger system or the dynamics is open. In statistical point of view there is in and out of energy from the system to the environment.

In unitary evolution case that is the quantum system  $S$  is closed to the environmental effects,  $|\psi\rangle$  is stable if it is the eigenstate of the system Hamiltonian.

$$H|\psi\rangle = E|\psi\rangle. \quad (4.1)$$

However in the most cases we have non-unitary evolution provided by the presence of the dissipative environment. Then we should talk about the density matrix

instead of state vectors. For stability we have required the condition that in the long time limit

$$\lim_{t \rightarrow \infty} \rho(t) = |\psi'\rangle\langle\psi'| \quad (4.2)$$

or

$$\langle\psi'|H|\psi'\rangle = \min_{\psi \in \mathbf{H}} \langle\psi|H|\psi\rangle. \quad (4.3)$$

If the resulting vector  $|\psi'\rangle$  is one of the maximally entangled states obtained from the maximum principle

$$V(\psi_{ME}) = \max_{\psi \in \mathbf{H}_S} V_{tot}(\psi) \quad (4.4)$$

and it satisfies the stability condition

$$\langle\psi'_{ME}|H|\psi'_{ME}\rangle = \min_{\psi \in \mathbf{H}} \langle\psi|H|\psi\rangle, \quad (4.5)$$

this state is maximally entangled as well as robust. The Mini-max principle [51] is a general principle applicable to whole range of physical systems. In the next section we will demonstrate an example.

## 4.2 An Example: Entanglement of two $\Lambda$ -type atoms

The generation and manipulation of entangled states in atom-photon systems has recently attracted a great deal of interest in the context of quantum information processing and quantum computing [52, 53, 54, 55, 56, 57, 58]. In particular, the entangled states were engineered through the use of cavity QED [52] and technique of ion traps [54]. Most studies on entanglement in atomic systems have used the two-level atoms, interacting with photons via dipole transitions [4, 5, 59]. It was shown that a pure entangled state of two atoms in an optical resonator can be obtained through the exchange by a single photon. Since the excitation of the system either is carried by a cavity photon or is shared between the atoms, the absence of the photon leakage from the resonator can be associated with the presence of atomic entanglement. This entanglement can be observed in



the process of continuous monitoring of the cavity decay[4]. The importance of this scheme is caused by the fact that its realization seems to be easily available with present experimental technique. The result can also be generalized on the multi-atom systems[6].

The lifetime of maximum entangled state (MES) in atomic subsystem is chiefly determined by the life of excited atomic state, that is by the natural line breadth. Usually, this time is quite short [60, 61]. At the same time, the quantum information processing needs more or less durable entanglement.

According to the result obtained in the previous section, the maximum entanglement in a system corresponds to the maximum total local variance, describing the quantum fluctuations of all local measurements. Thus, to achieve a long-lived maximum entanglement, we should first prepare a state with maximum quantum fluctuations and then stabilize it by draining energy right up to a (local) minimum, conserving at the same time the level of quantum fluctuations. This can be done via an interaction with a proper environment.

In view of the practical realization, it seems to be more convenient if the existence of atomic entanglement would manifest itself via a certain signal photon rather than via the absence of photons as in Ref.[4]. This implies that there should be at least two different modes interacting with the atoms such that the photon of one of them provides the correlation between the atoms, while the photon of the other mode can freely leave the resonator to signalize the rise of atomic entanglement.

In this example we discuss a way how to obtain a durable maximum entangled state of atoms in an optical resonator which can be monitored through the detection of signal photons.

Consider the Raman-type process in a three-level atom shown in Fig.4.1. Here  $1 \leftrightarrow 2$  and  $2 \leftrightarrow 3$  are the dipole transitions corresponding to the pump and Stokes modes, while the dipole transition between the levels 1 and 3 is forbidden because of the parity conservation. We assume that the two identical atoms of this type are located in a high-quality cavity tuned to resonance with  $1 \leftrightarrow 2$  transition,

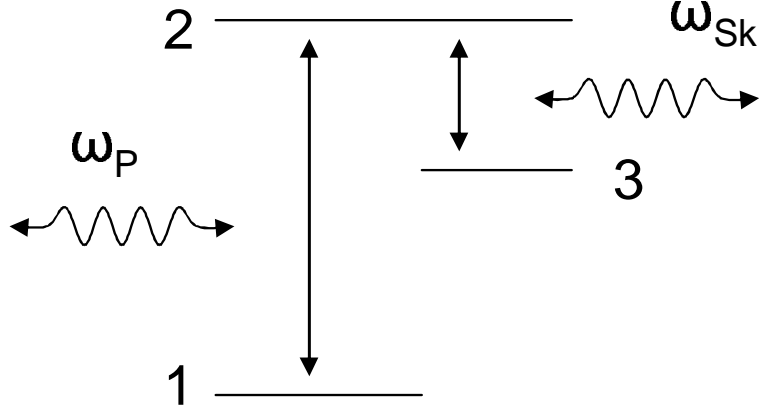

Figure 4.1: Scheme of Raman-type process in an atom. Solid arrows show the allowed transitions. Wavy lines show the pump and Stokes photons, respectively.

while the Stokes photons can leak away freely (Fig. 4.2).

Assume that initially both atoms are in the ground state (level 1) and there is a single cavity photon, so that the initial state is

$$|\psi_0\rangle = |1, 1\rangle|1_P\rangle|V_S\rangle. \quad (4.6)$$

Here  $|n_P\rangle$  denotes the  $n$ -photon state of the cavity (pump) mode and  $|V_S\rangle$  denotes the vacuum state of the Stokes field. Then, the absorption of the cavity photon by atomic system should lead to the state

$$|\psi_1\rangle = \frac{1}{\sqrt{2}}(|2, 1\rangle + |1, 2\rangle)|0_P\rangle|V_S\rangle, \quad (4.7)$$

which manifests the entanglement of atoms excited to the level 2. This atomic entanglement is similar to that discussed in Ref.[4] and has a very short lifetime defined by the atom-field coupling constants for the allowed transitions. The decay of the excited atomic state Eq.(4.7) can either return the system into the initial state Eq.(4.6) or turn Eq.(4.7) into the state

$$|\psi_k\rangle = \frac{1}{\sqrt{2}}(|3, 1\rangle + |1, 3\rangle)|0_P\rangle|1_{Sk}\rangle, \quad (4.8)$$

where  $|n_{Sk}\rangle$  denotes the state of  $n$  Stokes photons with frequency  $\omega_{Sk}$ . This state again manifests the maximum atomic entanglement. Since the cavity walls

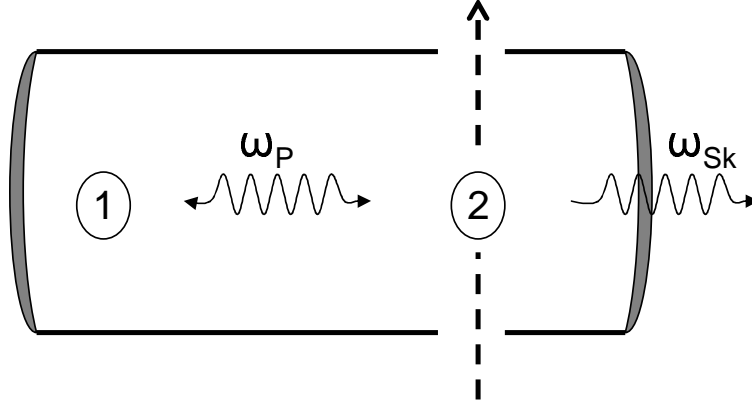

Figure 4.2: Scheme of creation of a durable two-atom entanglement. Atom 1 is trapped in a cavity, while atom 2 can pass through the cavity. Wavy lines show the cavity and leaking out Stokes photons.

are supposed to be transparent for the Stokes photons and  $3 \leftrightarrow 1$  is the dipole-forbidden transition, the atomic entanglement described by Eq.(4.8) would exist for a very long time determined by the weak interaction between the atoms excited to the level 3 and a certain dissipative environment. The creation of this atomic entanglement manifests itself by the Stokes photon that can be detected outside the cavity.

It should be noted that, in addition to  $|\psi_1\rangle$  and  $|\psi_k\rangle$ , the following maximum entangled states

$$|\phi_1\rangle = \frac{1}{\sqrt{2}}(|2, 1\rangle - |1, 2\rangle)|0_P\rangle|V_S\rangle,$$

$$|\phi_k\rangle = \frac{1}{\sqrt{2}}(|3, 1\rangle - |1, 3\rangle)|0_P\rangle|1_{Sk}\rangle$$

also contribute into the base states of the system under consideration. Both of them are stable states but they cannot be achieved in the process of evolution beginning with the initial state Eq.(4.6) (see Ref.[4]). Therefore, they can be discarded.

To describe the quantum dynamics of the system, we note that the upper atomic level  $|2\rangle$  can be adiabatically removed [62] (also see Ref.[63] and references therein). In this case, the two-photon transitions in effective two-level atoms

described by the effective interaction Hamiltonian

$$H_{int} = \sum_k \sum_{f=1}^2 \lambda_k \{R_{31}(f)a_{S_k}^+ a_P + H.c\} \quad (4.9)$$

should be considered. Here  $\lambda_k$  denotes an effective coupling constant has been defined in Ref. [62] and  $R_{ij}(f)$  is the atomic operator corresponding to the transition  $j \rightarrow i$  in the  $f$ -th atom. Under the influence of Eq.(4.9), the initial state Eq.(4.6) is directly transformed into Eq.(4.8), so that the intermediate entangled state Eq.(4.7) can be omitted. Then, the time-dependent wave function of the system takes the form

$$|\Psi(t)\rangle = C_0(t)|\psi_0\rangle + \sum_k C_k(t)|\psi_k\rangle, \quad (4.10)$$

where the time-dependent coefficients are defined by the Schrödinger equation together with the initial condition

$$|\Psi(0)\rangle = |\psi_0\rangle, \quad C_0(0) = 1, \quad C_k(0) = 0. \quad (4.11)$$

Taking into account that the total Hamiltonian has the form

$$H = H_0 + H_{int},$$

$$H_0 = \omega_P a_P^+ a_P + \sum_k \omega_{S_k} a_{S_k}^+ a_{S_k} + \omega_{31} \sum_{f=1}^2 R_{33}(f),$$

we get the following system of linear differential equations

$$i\dot{C}_0 = \omega_P C_0 + \sum_k \lambda_k \sqrt{2} C_k,$$

$$i\dot{C}_k = (\omega_{S_k} + \omega_{31}) C_k + \lambda_k \sqrt{2} C_0. \quad (4.12)$$

Here  $\omega_{31} = E_3 - E_1$  denotes the energy difference between the levels  $|3\rangle$  and  $|1\rangle$  connected by the two-photon transition. These Eqs.(4.12) together with the initial conditions Eq.(4.11) completely determine the evolution of the state Eq.(4.10). Using the standard methods [64], it is easy to show that the system evolves from the initial state Eq.(4.6) into the final state

$$|\Psi(t)\rangle \rightarrow \sum_k J_k |\psi_k\rangle,$$

corresponding to the maximum atomic entanglement described by Eq.(4.8). Here

$$J_k = \frac{-i\lambda_k\sqrt{2}}{\gamma/2 - i(\omega_{Sk} + \omega_{31} - \omega_P - \Delta)},$$

and

$$\gamma = 2\pi p(\omega_{Sk})\lambda_k^2|_{\omega_{Sk}+\omega_{31}=\omega_P}$$

is the parameter describing the rapidity of the exponential evolution to the entangled atomic state,  $p(\omega_k)$  denotes the density of states corresponding to the Stokes field, and

$$\Delta = -\mathcal{P} \left\{ \int_{-\infty}^{\infty} \frac{p(\omega_{Sk})\lambda_k^2 d\omega_k}{\omega_k + \omega_{31} - \omega_P} \right\}$$

is a small frequency shift ( $\mathcal{P}$  denotes the principle value of the integral). Thus

$$\begin{aligned} |\Psi(t)\rangle &= e^{-\gamma t/2} e^{-i(\omega_P - \Delta)t} |\psi_0\rangle \\ &- \sum_k \frac{i\lambda_k\sqrt{2}}{\gamma/2 - i(\omega_{Sk} + \omega_{31} - \omega_P - \Delta)} \times \\ &\times (e^{-i(\omega_{Sk} + \omega_{31})t} - e^{-\gamma t/2} e^{-i(\omega_P - \Delta)t}) |\psi_k\rangle \end{aligned}$$

and the system evolves exponentially to the maximum entangled atomic state Eq.(4.8). In fact, this is a durable maximum entangled atomic state because the direct single-photon transition  $|3\rangle \leftrightarrow |1\rangle$  is forbidden. The lifetime of this entangled state is defined by the slow non-radiative processes only.

Let us stress that the two advantages of the above considered three-level two-photon process in comparison with the previous scheme [4, 5] are on the one hand the durability of the entangled state and on the other hand the simple monitoring of entanglement via detection of Stokes photon. We reckon that the quantum information processing in the system under consideration can be arranged in the same way as in Ref.[65].

The above long-life atomic entanglement can be interpreted as the long-distance entanglement as well within the following experimental scheme. Assume that one of the atoms is trapped in the cavity which supports a single-photon Fock state of the pump mode. The second atom passes through the cavity as

shown in Fig. (4.2). Time of the propagation of the atom through the cavity defined by the velocity of the atom should be long enough to provide the preparing of the entangled state Eq.(4.8) with high probability. The creation of this state is signaled by detection of the Stokes photon. Then, the measurement of the state of the moving atom at any distance from the cavity uniquely determines the state of the trapped atom.

Concerning the practical realization of the above discussed scheme, we should stress that the observation of single-atom Raman-type process in an optical cavity has been reported recently [66]. In this work, the  $^{85}\text{Rb}$  atom was used. The excited state  $|2\rangle$  corresponds to  $5P_{3/2}$  level, while the ground  $|1\rangle$  and intermediate  $|3\rangle$  states are the  $5S_{1/2}$  hyperfine levels separated by frequency  $\omega_{31} = 3\text{GHz}$ , while Stokes field has the wavelength  $\lambda_S = 780\text{nm}$ . In this case, the lifetime of the state  $|3\rangle$  is at least ten times longer than that for the excited state  $|2\rangle$ .

Let us stress that the obtained result can be generalized on the multi-atom case [69, 70, 71] in the same way as for the conventional single-photon process in two-level atoms [6]. The increase of the number of atoms should lead to a speeding-up of the evolution to the entangled atomic state because of the Dicke-type process caused by the photon exchange between the atoms (see Ref.[67]).

### 4.3 Summary

In this chapter we have discussed how to obtain robust entangled states as well as maximally entangled states. We have defined a new practical principle *Mini-max principle* applicable for all range of physical systems. At the last part of the chapter we have demonstrated the effect of the principle on  $2 - \Lambda$  type atoms in a cavity for obtaining maximally entangled and robust states [68] which are immune to the spontaneous decay of the individual atoms.

# Chapter 5

## Entanglement of Photons

In this chapter we will discuss the polarization properties of the photons produced by an atomic transition from a localized atom [72]. We have used spherical wave representation to describe quantum properties of multipole radiation.

### 5.1 Introduction

It is well known that the time-varying classical electromagnetic (EM) field can be expanded in vector spherical waves and that this representation is convenient for electromagnetic boundary-value problems possessing spherical symmetry and for the discussion of multipole radiation from a local sources (e.g., see Ref.[73, 8]). Since both plane and spherical waves form complete sets of orthonormal functions, they are equivalent, so that the use of either representation of classical electromagnetic radiation is caused by the usability reasons.

The underlying motive for consideration of quantum EM radiation in terms of spherical waves of photons is the fact that the atomic and molecular transitions create the multipole photons, in other words, the photons with given angular momentum and parity rather than plane photons specified by the linear momentum and polarization [74, 11].

Although there is no principle difference between the plane and spherical waves within the classical domain since both represent the complete orthogonal sets of solutions of the homogeneous wave equation [8] and can be re-expanded with respect to each other, the quantum counterparts of these two representations are non-equivalent because they describe the physical quantities (the linear and angular momenta respectively) which cannot be measured at once. The point is that the vector potential of classical EM field is defined in the three-dimensional Euclidian space  $\mathcal{R}^3$ , while the operator vector potential of quantum EM radiation is defined in the space

$$\mathcal{H} = \mathcal{R}^3 \otimes \mathbf{H}_{\text{ph}}, \quad (5.1)$$

where  $\mathbf{H}_{\text{ph}}$  denotes the Hilbert space of photons.

According to Wigner's approach [75], *the general properties of a quantum mechanical system are specified by the dynamic symmetry of the corresponding Hilbert space.* The Hilbert spaces of plane and spherical photons have different symmetry properties. Viz, the former manifests the  $SO(2)$  symmetry caused by invariance with respect to rotations in  $xy$ -plane whose positive normal coincides with direction of propagation  $\vec{k}/k$ . In turn, the latter has the  $SU(2)$  symmetry agreed upon the invariance with respect to rotations in three dimensions about a local source (say, atom or molecule).

In particular, the symmetry reasons imply the different sets of quantum numbers, specifying the photons in the two representations [74, 11, 10]. A photon in the plane wave representation (PWR) is specified by given energy, linear momentum, and polarization. In turn, a photon in the spherical wave representation (SWR) has given energy, angular momentum, and parity that corresponds to the type of radiation, either electric or magnetic.

A number of modern experiments with trapped atoms interacting with photons corresponds to the interatomic distances that are much shorter than the wave length [76, 77]. It should be stressed that the difference between the properties of photons in PWR and SWR is particularly strong just in the near and intermediate zones.



Another reason to use SWR is connected with the problem of use of the angular momentum (AM) of photons in quantum information processing that has attracted recently a great deal of interest [78, 79, 80, 81, 82].

## 5.2 Quantization of Multipole Radiation

Following [10], let us construct a representation of photons with given AM and parity. This means that we have to represent the vector potential in terms of a superposition of states with given AM and parity.

As for any other particle, AM of a photon consists of the spin and OAM contributions. Since rest mass of photons is equal to zero, the spin is defined to be the minimum possible value of AM. From the atomic spectroscopy we know that the minimum  $j = 1$  (in the units of  $\hbar$ ). Thus, the angular momentum of a photon is

$$\vec{J} = \vec{S} + \vec{L}, \quad (5.2)$$

where  $\vec{S}$  and  $\vec{L}$  denote the spin and OAM, respectively. The eigenfunctions of the operators  $J_z$  and  $\vec{J}^2$  are the *vector spherical harmonics* [8, 74, 83]

$$\vec{J}^2 \vec{Y}_{j\ell m} = j(j+1) \vec{Y}_{j\ell m}, \quad J_z \vec{Y}_{j\ell m} = m \vec{Y}_{j\ell m}. \quad (5.3)$$

The eigenstates of spin 1 are the columns

$$\vec{\epsilon}_+ = \begin{pmatrix} 1 \\ 0 \\ 0 \end{pmatrix}, \quad \vec{\epsilon}_0 = \begin{pmatrix} 0 \\ 1 \\ 0 \end{pmatrix}, \quad \vec{\epsilon}_- = \begin{pmatrix} 0 \\ 0 \\ 1 \end{pmatrix},$$

that can be associated with the base vectors in  $\mathcal{R}^3$  as follows

$$\vec{\epsilon}_\pm = \mp \frac{\vec{e}_x \pm i\vec{e}_y}{\sqrt{2}}, \quad \vec{\epsilon}_0 = \vec{e}_z. \quad (5.4)$$

In fact, the vectors (5.4) form the so-called helicity basis [8, 84]. In particular, the vectors  $\vec{\epsilon}_\pm$  can be associated with unit vectors of polarization with either positive

or negative helicity. Let us stress that quantum electrodynamics interprets the polarization as a given spin state of photons [74].

In turn, the eigenstates of quantum mechanical OAM operator  $-i(\vec{r} \times \vec{\nabla})$  are the spherical harmonics  $Y_{\ell m}(\vec{k}/k)$ . Thus, the vector spherical harmonics (5.3) can be constructed as the linear combinations of spin states and spherical harmonics

$$\vec{Y}_{j\ell m} = \sum_{\mu} \langle 1\ell\mu, m - \mu | jm \rangle \vec{\epsilon}_{\mu} Y_{\ell, m - \mu}, \quad (5.5)$$

where  $\langle \dots | \dots \rangle$  denotes the Clebsch-Gordon coefficients of vector addition of spin and OAM. Taking into account the properties of Clebsch-Gordon coefficients [85], it is easy to conclude that the quantum numbers  $j$  and  $\ell$  connected in the following way

$$j = \ell + 1, \ell, |\ell - 1|. \quad (5.6)$$

Thus, for each value of AM  $j$ , there are three different states specified by the vector spherical harmonics (5.5) under the condition (5.6).

Since under inversion  $\vec{\epsilon}_{\mu}$  changes sign and function  $Y_{\ell, m - \mu}$  is multiplied by  $(-1)^{\ell}$ , the vector spherical harmonics have given parity  $(-1)^{\ell+1}$ . Thus, the functions  $\vec{Y}_{jjm}$  have the parity  $(-1)^{j+1}$ , while the parity of functions  $\vec{Y}_{j, j \pm 1, m}$  is  $(-1)^j$ .

The vector spherical harmonics (5.5) form a complete orthonormal set of functions:

$$\int_0^{2\pi} d\phi \int_0^{\pi} \vec{Y}_{j\ell m}^+ \cdot \vec{Y}_{j'\ell'm'} \sin\theta d\theta = \delta_{jj'} \delta_{\ell\ell'} \delta_{mm'}. \quad (5.7)$$

It is seen that  $(\vec{k}/k) \cdot \vec{Y}_{jjm}(\vec{k}/k) = 0$ . This function  $\vec{Y}_{jjm}$  is usually told the *transversal vector spherical harmonics of magnetic type*. Another transversal function can be constructed as a combination of the functions with  $\ell = j \pm 1$

$$\vec{Y}_{jm}^E \equiv \frac{1}{\sqrt{2j+1}} (\sqrt{j} \vec{Y}_{j, j+1, m} + \sqrt{j+1} \vec{Y}_{j, j-1, m}), \quad (5.8)$$

which is called the *transversal spherical harmonics of electric type*. It is seen that  $\vec{Y}_{jjm}$  and  $\vec{Y}_{jm}^E$  are mutually orthogonal for the same  $\vec{k}/k$ .

The functions with  $\ell = j \pm 1$  can also be used to construct the *longitudinal vector spherical function*

$$\vec{Y}_{jm}^L = -\sqrt{\frac{j+1}{2j+1}}\vec{Y}_{j,j+1,m} + \sqrt{\frac{j}{2j+1}}\vec{Y}_{j,j-1,m},$$

which is orthogonal to both  $\vec{Y}_{jjm}$  and  $\vec{Y}_{jm}^E$ . Nevertheless, this longitudinal function should be discarded because the Poincaré invariance allows only two degrees of freedom for a particle on the light cone.

Thus, the states of the field with given AM and parity can be obtained by expansion of vector potential over the transversal vector spherical harmonics. Taking into account the expansion [8]

$$e^{i(\vec{k}\cdot\vec{r}-\omega_k t)} = 4\pi \sum_{\ell,m} (i)^\ell j_\ell(kr) Y_{\ell m}^*(\vec{k}/k) Y_{\ell m}(\vec{k}/k) e^{-i\omega_k c},$$

where  $j_\ell(kr)$  denotes the spherical Bessel function, we can conclude that the positive-frequency part of the vector potential has the form

$$\vec{A}_{Mkjm} = N_M j_\ell \vec{Y}_{jjm} a_{Mkjm}, \quad (5.9)$$

$$\vec{A}_{Ekjm} = N_E [\sqrt{j} j_{j+1}(kr) \vec{Y}_{j,j+1,m} - \sqrt{j+1} j_{j-1}(kr) \vec{Y}_{j,j-1,m}] a_{Ekjm} \quad (5.10)$$

in the case of parity  $(-1)^{j+1}$  and  $(-1)^j$ , respectively. Here  $N_\lambda$  denotes the normalization factor. In order to have vector potential with discrete values of  $k$ , the right-hand sides in (5.9) and (5.10) should be defined inside an ideal spherical cavity of big radius  $R$ . Then, the spectrum is defined by the roots of equation

$$j_\ell(kR) = 0.$$

In this case, it is convenient to renormalize the spherical Bessel functions by the condition

$$\forall \ell \quad \int_0^R j_\ell(kr) j_\ell(k'r) r^2 dr = \frac{4\pi R^3}{3} \delta_{kk'}.$$

In Eqs. (5.9) and (5.10), the complex amplitudes  $a_{\lambda k jm}$  specify the amount of the corresponding multipole field. The harmonic time dependence is usually included into these amplitudes. In classical electrodynamics, the amplitudes  $a_{\lambda k jm}$  are determined by the properties of the source of radiation (harmonically varying

current or intrinsic magnetization) [8]. Within the quantum picture, the amplitudes  $a_{\lambda k j m}$  are supposed to be the annihilation operators of multipole photons [10, 83] that obey the commutation relations

$$[a_{\lambda k j m}, a_{\lambda' k' j' m'}^+] = \delta_{\lambda \lambda'} \delta_{k k'} \delta_{j j'} \delta_{m m'}. \quad (5.11)$$

Hence, they form a representation of the Weyl-Heisenberg algebra of multipole photons. In this case, (5.9) and (5.2) should be considered as the positive frequency parts of the *operator vector potential* of the magnetic-type radiation (with  $\lambda = M$  and parity  $(-1)^{j+1}$ ) and of the electric-type radiation (with  $\lambda = E$  and parity  $(-1)^j$ ), respectively.

Hereafter, we consider expressions (5.9) and (5.10) as the quantum operators.

Let us now note that the operators (5.9) and (5.10) can be represented in  $\mathcal{R}^\ni$  as follows

$$\vec{A}_{\lambda k j m} = \sum_{\mu} (-1)^{\mu} \epsilon_{-\mu} \mathcal{A}_{\lambda k j m \mu} a_{\lambda k j m},$$

where  $\mathcal{A}_{\lambda k j m \mu}$  denotes the *mode function* of the multipole field. By construction, this function obey the homogeneous Helmholtz wave equation

$$\nabla^2 \mathcal{A}_{\lambda k j m \mu} + \omega_k^2 \mathcal{A}_{\lambda k j m \mu} = 0.$$

In fact, the vector  $\vec{A}_{\lambda k j m}$  can be considered as a function from  $\mathcal{R}^\ni$  to the Hilbert space  $\mathcal{H}$  of complex linear functions on  $\mathcal{R}^\ni$  in (5.1). The operators (5.9) and (5.10) obey the same wave equations but assumes values in the Hilbert space  $\mathcal{H} \times \mathcal{H}$ , where the second factor  $\mathcal{H}$  comes from the spin states.

In view of the wave equation, the mode functions  $\vec{A}_{\lambda k j m}$  can be interpreted as the *wave functions of multipole photons* [74].

It should be emphasized that under rotations the vector spherical functions are transformed along an irreducible representations of the  $O^+(3)$  group. Thus, they are the irreducible tensors of rank  $j$  rather than vectors.

It is useful to show that the operators (5.9) and (5.10) are invariant with respect to the  $SU(2)$  group. Consider first the electric-type multipole radiation

and introduce an auxiliary operator

$$\vec{\mathbf{A}}_\ell(\vec{r}/r) = \sum_{\mu,m} Y_{1\mu} Y_{\ell m} \vec{\epsilon}_\mu \otimes a_{\ell m} \quad (5.12)$$

For simplicity, we drop here all other indexes. Because rotations do not influence the radial dependence in (5.10) provided by the spherical Bessel functions, the auxiliary function (5.12) depends only on the direction  $\vec{r}/r$  in  $\mathcal{R}^\exists$ .

Let  $\varphi$  be an arbitrary transformation belonging to the  $SU(2)$  group. Then

$$\begin{aligned} \vec{\mathbf{A}}_\ell(\varphi\vec{r}/r) &= \sum_{\mu,m} Y_{1\mu}(\varphi\vec{r}/r) Y_{\ell m}(\varphi\vec{r}/r) \\ &= \sum_{\mu,\mu'} \sum_{m,m'} Y_{1\mu'}(\vec{r}/r) \varphi_{\mu\mu'} Y_{\ell m'}(\vec{r}/r) \vec{\epsilon}_\mu \otimes \varphi_{mm'} a_{\ell m} \\ &= \sum_{\mu,\mu'} \sum_{m,m'} Y_{1\mu'}(\vec{r}/r) Y_{\ell m'}(\vec{r}/r) [\varphi_{\mu\mu'} \vec{\epsilon}_\mu] \otimes [\varphi a_{\ell m}] \\ &= \sum_{m\mu',m'} Y_{1\mu'}(\vec{r}/r) Y_{\ell m'}(\vec{r}/r) [\varphi \vec{\epsilon}_{\mu'}] \otimes [\varphi a_{\ell m}] = \varphi \vec{\mathbf{A}}_\ell(\vec{r}/r). \end{aligned}$$

Thus, the auxiliary operator (5.12) is invariant with respect to the  $SU(2)$  group.

Since the spherical harmonics form a basis of an irreducible representation  $\mathbf{M}_\ell$  of the  $SU(2)$  group, the product  $Y_{1\mu} Y_{\ell m}$  in (5.12) form a basis of

$$\mathbf{M}_1 \otimes \mathbf{M}_\ell = \mathbf{M}_{\ell-1} \oplus \mathbf{M}_\ell \oplus \mathbf{M}_{\ell+1}. \quad (5.13)$$

The operator (5.10) is defined just in (5.13).

Let  $(Y_{1\mu} Y_{\ell m})_s$  ( $s = \ell, \ell \pm 1$ ) be the component (projection) of  $Y_{1\mu} Y_{\ell m}$  in  $\mathbf{M}_s$ . Then the vector operator

$$\vec{\mathbf{A}}_{\ell s} = \sum_{\mu,m} (Y_{1\mu} Y_{\ell m})_s \vec{\epsilon}_\mu \otimes a_{\ell m}$$

is also invariant with respect to the  $SU(2)$  group. This implies the invariance of (5.10), because rotations do not influence the radial dependence. The  $SU(2)$  invariance of (5.9) can be proven in the same way.

### 5.3 Angular Momentum of Multipole Photons

A classical distribution of electromagnetic field in vacuum carries AM of the form

$$\vec{J} = \frac{1}{4\pi c} \int \vec{r} \times (\vec{E} \times \vec{B}) d^3r, \quad (5.14)$$

where

$$\vec{E} = \frac{1}{c} \frac{\partial \vec{A}}{\partial t}, \quad \vec{B} = \vec{\nabla} \times \vec{A}$$

are the electric and magnetic fields. For the fields produced a finite time in the past and so localized to a finite region, this expression can be rewritten in the form

$$\vec{J} = \frac{1}{4\pi c} \int \left[ \vec{E} \times \vec{A} + \sum_{\mu} E_{\mu} (\vec{r} \times \vec{\nabla}) B_{\mu} \right] d^3r. \quad (5.15)$$

The first term is usually identified with the spin contribution, while the second term represents OAM because of the presence of the quantum mechanical angular momentum operator  $-i(\vec{r} \times \vec{\nabla})$  [9]. Let us stress that Eq. (5.15) is obtained within the classical picture, so that the use of notions of spin and OAM has a conditional meaning.

Within the quantum domain, both terms in the right-hand side of (5.15) are represented by the bilinear forms in the photon operators (5.11). Since within the quantization scheme [73, 10, 9]  $\vec{E}$  and  $\vec{A}$  are usually associated with the canonical variables of the field, the first term in (5.15) can be interpreted as an intrinsic AM of a photon.

Consider first PWR, when the operator vector potential has the form

$$\vec{A}(\vec{r}) = N \sum_{\mu=\pm} \sum_k \vec{\epsilon}_{k\mu} (e^{i\vec{k}\cdot\vec{r}} a_{k\mu} + H.c.)$$

because the third direction  $\epsilon_{k0}$  is forbidden in this case [9]. Averaging the first term in the right-hand side of (5.15) over time to eliminate the rapidly oscillation terms with  $a^2$  and  $(a^+)^2$  and changing summation over  $k$  by integration, we get for the spin operator

$$\vec{S} = \frac{N^2}{2\pi c} \int \frac{d^3k}{2\pi} \vec{k} (a_{k+}^+ a_{k+} - a_{k-}^+ a_{k-}). \quad (5.16)$$

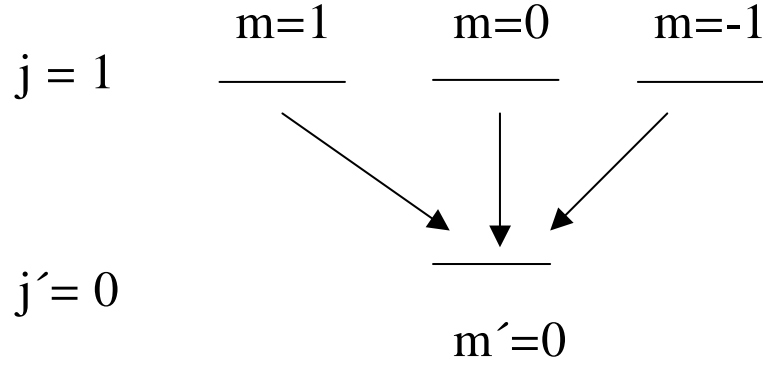

Figure 5.1: Energy diagram of triple degenerated excited and ground states of a dipole transition  $j = 1 \leftrightarrow j' = 0$ .

Thus, the photons with given energy, linear momentum and polarization  $\mu = \pm 1$  in PWR have no spin about  $z$ -axis defined by the direction of propagation. In particular, this leads to the wrong commutation relations for the components of the operator (5.16) [78, 86]:

$$[S_\alpha, S_\beta] = 0, \quad \alpha, \beta = x, y, z. \quad (5.17)$$

We now show that this result can be improved through the use of SWR. Consider first a single-mode photon emitted by an electric dipole (E1) transition in a two-level atom located at the center of an ideal spherical cavity. Let us stress that E1 photons represent the most frequently encountered type of EM radiation in visible and IR regions. If AM of the excited atomic state is  $j = 1$ , then this state is triple degenerated with respect to the quantum number  $m = 0, \pm 1$ , see Fig.(5.1) The Jaynes-Cummings Hamiltonian of such a system has the form [87]

$$\begin{aligned} H &= H_0 + H_{int}, \\ H_0 &= \sum_m (\omega a_m^+ a_m + \omega_0 R_{mm}), \\ H_{int} &= \gamma \sum_m (R_{mg} a_m + a_m^+ R_{gm}). \end{aligned} \quad (5.18)$$

Here  $\omega$  is the cavity mode frequency,  $\omega_0$  is the atomic transition frequency,  $\gamma$  is the coupling constant,  $a_m, a_m^+$  are the E1 photon operators (5.11), and  $R$  denotes the atomic operators:

$$R_{mm'} = |j = 1, m\rangle \langle j = 1, m|, \quad R_{mg} = |j = 1, m\rangle \langle j' = 0, 0|.$$

Since the angular momentum is conserved in the atom-photon interaction [11], the total angular momentum

$$\vec{J} = \vec{J}^{(a)} + \vec{J}^{(ph)} \quad (5.19)$$

should be an integral of motion with the Hamiltonian (5.18). Here the superscripts denote the atom and photon contributions. It is clear that the photon, created by the atom, takes away AM of the excited atomic state. The latter is specified by the operators

$$\begin{aligned} J_x^{(a)} &= \frac{1}{\sqrt{2}}(R_{0+} + R_{0-} + H.c.), \\ J_y^{(a)} &= \frac{1}{\sqrt{2}}(R_{0+} - R_{0-} - H.c.), \\ J_z^{(a)} &= R_{++} - R_{--}, \end{aligned} \quad (5.20)$$

that obey the commutation relations

$$[J_\alpha^{(a)}, J_\beta^{(a)}] = i\epsilon_{\alpha\beta\kappa} J_\kappa^{(a)}, \quad \alpha, \beta, \kappa = x, y, z. \quad (5.21)$$

It is now a straightforward matter to arrive at conclusion that the photon operator, complementing (5.20) with respect to the integral of motion with the Hamiltonian (5.18), has the components

$$\begin{aligned} J_x^{(ph)} &= \frac{1}{\sqrt{2}}\{a_0^+(a_+ + a_-) + H.c.\}, \\ J_y^{(ph)} &= \frac{i}{\sqrt{2}}\{a_0^+(a_+ - a_-) - H.c.\}, \\ J_z^{(ph)} &= a_+^+ a_+ - a_-^+ a_-. \end{aligned} \quad (5.22)$$

It follows from (5.11) that the operators (5.22) obey the same commutation relations as (5.21), that are the true commutation relations for the components of AM operator. By construction, the operators (5.22) define AM carried away by the photon from the atom. Thus, the use of SWR leads to the true commutation relations for AM of photons.

Let us stress a principle difference in the operator structure of Eqs. (5.15) and (5.22). In the former, the symbols  $\pm$  denote the circular polarization, while in the latter, the subscripts  $m = 0, \pm 1$  correspond to the projection of angular momentum  $j = 1$  on the quantization axis.



Assume that the atom emits E1 photon with given  $m$ . Then, for the mean values of AM operators (5.21) we get

$$\forall m \quad \langle 1_m | J_{x,y}^{(ph)} | 1_m \rangle = 0, \quad \langle 1_m | J_z^{(ph)} | 1_m \rangle = m.$$

In turn, the variances are

$$\langle 1_m | (\Delta J_{x,y}^{(ph)})^2 | 1_m \rangle = \begin{cases} \frac{1}{2}, & \text{at } m = \pm 1 \\ 1, & \text{at } m = 0 \end{cases}$$

and

$$\langle 1_m | (\Delta J_z^{(ph)})^2 | 1_m \rangle = |m|.$$

Thus, the Fock number state of E1 photon manifests strong quantum fluctuations of AM.

Eqs. (5.21) can be used to specify mean values and variances of AM of many E1 photons as well. Assume for example that the local source emits E1 photons in coherent state  $|\alpha_m\rangle$  with given  $m$ . Then

$$\langle \alpha_m | J_{x,y}^{(ph)} | \alpha_m \rangle = 0, \quad \langle \alpha_m | J_z^{(ph)} | \alpha_m \rangle = m |\alpha_m|^2$$

and

$$\langle \alpha_m | (\Delta J_{x,y}^{(ph)})^2 | \alpha_m \rangle = \begin{cases} \frac{1}{2} |\alpha_{\pm}|^2, & m = \pm 1 \\ |\alpha_0|^2, & m = 0 \end{cases}, \quad \langle \alpha_m | (\Delta J_z^{(ph)})^2 | \alpha_m \rangle = |m| |\alpha_m|^2.$$

Thus, the state of radiation with  $m = 0$  again manifests more strong quantum fluctuations of the components of AM. In PWR, the operators  $J_{x,y}^{(ph)}$  do not fluctuate at all.

Let us now establish a contact with the definitions of AM given by Eqs. (5.13) and (5.14). Consider first the spin density operator

$$\vec{S}(\vec{r}) = \frac{1}{4\pi c} \vec{E}(\vec{r}) \times \vec{A}(\vec{r}) \quad (5.23)$$

in the case of E1 monochromatic radiation. Using (5.10), one can see that the components of (5.23) contain all possible bilinear combinations of photon operators (5.11). Taking into account the property of spherical Bessel functions that

$j_0(kr) \rightarrow 1$  and  $j_2(kr) \rightarrow 0$  at  $r \rightarrow 0$ , we can conclude that the components of the spin operator (5.23) have the same structure in the photon operators as (5.21). Moreover, it is seen that the integrand of the second term in (5.14) vanish in the same limit. Thus, in a certain vicinity of the origin (atom), AM of photons consists of spin while OAM contribution arises with distance from the source.

Taking into account that the photon localization appears in the form of a wavefront [88], we should integrate (5.23) over a spherical shall of radius  $r$  together with averaging over time to calculate the amount of spin carried by E1 photon at any distance  $r$  from the source. Performing straightforward but tedious calculations, we can conclude that

$$\vec{\mathcal{S}}(r) \equiv \int_0^{4\pi} d\phi \int_0^\pi \vec{S}(\vec{r}) \sin \theta d\theta = f(kr) \vec{J}^{(ph)}, \quad f(kr) \sim j_0^2(kr) - j_2^2(kr)/4.$$

In turn, OAM of E1 photons at distance  $r$  from the source can be calculated in the same fashion as  $\vec{\mathcal{S}}(r)$ :

$$\vec{\mathcal{L}}(r) \equiv \int_0^{4\pi} d\phi \int_0^\pi \vec{L}(\vec{r}) \sin \theta d\theta \sim j_2^2(kr) \vec{j}.$$

The fact that OAM has the same operator structure as the spin and total AM reflects the known property of electric-type photons [74, 83]. Viz, in the states described by the vector spherical harmonics of electric type (5.8), OAM does not have a given value but is a superposition of states with  $\ell = j \pm 1$ . Thus, in these states, the total AM *cannot be divided into spin and OAM contributions*.

A more detailed examination shows that, unlike the energy of electromagnetic field, AM is not contained in the pure wave zone and the main contribution to AM comes from the near and intermediate zones.

The situation becomes different as soon as we take into account continuum mode distribution corresponding to the natural line breadth. In this case, we should extend the model Hamiltonian (5.17) on the multi-mode case by adding integration over  $k$  and use the Markov approximation, which is similar to the Wigner-Weisskopf approach [89, 90]. Then, the time-dependent wave function of the atom-photon system can be written in the form

$$|\psi(t)\rangle = C(t)|\psi^{(a)}\rangle + \int B(k,t)|\psi(k)\rangle dk \quad (5.24)$$

with the initial conditions

$$C(0) = 1, \quad \forall k \quad B(k, 0) = 0.$$

Here  $|\psi^{(a)}\rangle$  corresponds to the excited atomic state and vacuum for photons, while  $|\psi(k)\rangle$  gives the ground atomic state and single E1 photon with given  $k$  and  $m$ . Employing the standard analysis than gives

$$C(t) = e^{-i\omega_0 t - \Gamma t}, \quad B(k, t) = \frac{-k^{3/2}}{\omega_k - \omega_0 + i\Gamma} \left(1 - e^{i(\omega_k - \omega_0) - \Gamma t}\right),$$

where  $\Gamma$  is the radiative decay width.

Carrying out the averaging of  $z$  components of spin and OAM contributions in (5.14) over the state (5.24), we get

$$\langle S_z(t) \rangle = \langle L_z(t) \rangle = \frac{1}{2}(1 - e^{-2\Gamma t}) \quad (5.25)$$

in the units of  $\hbar$ . Since the Markov approximation corresponds to the "rough" scale  $t \gg \Gamma^{-1}$  [90], Eq. (5.25) shows that spin and OAM contribute equally into the total AM of E1 photons at the distances  $r \geq c/\Gamma \gg c/\omega_0$ , corresponding to the wave zone.

The obtained results can also be applied to the problem of entanglement of photon twins created by an electric quadrupole (E2) transition between the states  $|j = 2, m = 0\rangle$  and  $|j' = 0, m' = 0\rangle$ . The cascade decay of this state gives rise to the two E1 photons propagating in the opposite directions, see Fig.(5.2). Because of the conservation law, the state of the radiation field has the form

$$|\psi\rangle = \frac{1}{\sqrt{3}}(|1_+, 1_-\rangle + |1_-, 1_+\rangle + |1_0, 1_0\rangle), \quad (5.26)$$

where the subscripts correspond to the quantum numbers  $m$  and  $|1_m, 1_{m'}\rangle$  is the product of number states of "left" and "right" photons. Let us stress that photons with  $m = 0$  may have the most probable direction of propagation different from that for the photons with  $m = \pm 1$  because of the structure of the radiation pattern.

We now show that (5.26) represent the maximum entangled qutrit state. It was shown in Refs. [6, 91] that the maximum entangled states of a composite

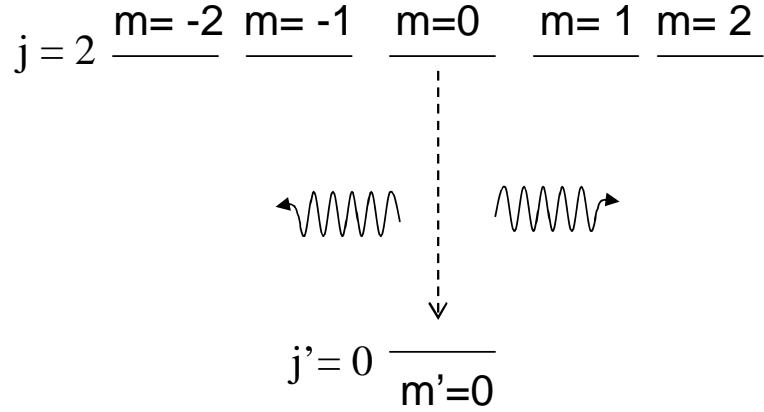

Figure 5.2: Generation of two E1 type photons from an atomic transition,  $j = 2 \rightarrow j' = 0$ .

system obey the following criterion. *The local measurements at all subsystems have maximum uncertainty in comparison with the other states allowed for a system under consideration.* The complete set of local measurements is defined by the dynamic symmetry group of the Hilbert state of the composite system [91]. In the case of qutrit system, this is the  $SU(3)$  group. Then, the local ("left" and "right") measurements in the system described by the state (5.26) are described by the nine Hermitian generators of the  $SU(3)$  subalgebra in the Weil-Heisenberg algebra of E1 photons (5.11):

$$M = \begin{cases} a_+^\dagger a_+ - a_0^\dagger a_0, & a_0^\dagger a_0 - a_-^\dagger a_-, & a_-^\dagger a_- - a_+^\dagger a_+, \\ \frac{1}{2}(a_+^\dagger a_0 + a_0^\dagger a_+), & \frac{1}{2}(a_0^\dagger a_- + a_-^\dagger a_0), & \frac{1}{2}(a_-^\dagger a_+ + a_+^\dagger a_-), \\ \frac{1}{2i}(a_+^\dagger a_0 - a_0^\dagger a_+), & \frac{1}{2i}(a_0^\dagger a_- - a_-^\dagger a_0), & \frac{1}{2i}(a_-^\dagger a_+ - a_+^\dagger a_-). \end{cases} \quad (5.27)$$

It is easily seen that

$$\langle \psi | M_n | \psi \rangle = 0 \quad \text{for all } n = 1, \dots, 9 \text{ in (5.27).}$$

Thus, the uncertainties of the measurements (5.27)

$$\langle (\Delta M_n)^2 \rangle \equiv \langle (M_n)^2 \rangle - \langle M_n \rangle^2$$

achieve the maximum value  $\langle (\Delta M_n)^2 \rangle = \langle (M_n)^2 \rangle$  in the case of averaging over the state (5.26).

Let us stress that similar qutrit states have been considered in the context of quantum information processing and quantum cryptography [92, 93].

It is easily seen that AM operators (5.22) can be constructed as the linear combinations of the generators (5.27). Thus,  $\langle J_\alpha^{(ph)} \rangle = 0$  in the state (5.26). At the same time, this state provides the maximum quantum fluctuations of the components of AM

$$\langle (\Delta J_\alpha^{(ph)})^2 \rangle = \frac{2}{3}, \quad \alpha = x, y, z,$$

as well as the maximum correlation of measurements at the opposite sides of the "quantum information channel" provided by the state (5.26):

$$\langle [J_\alpha^{(ph)}]_{left}, [J_\alpha^{(ph)}]_{right} \rangle = \frac{2}{3}.$$

Here  $\langle A, B \rangle \equiv \langle AB \rangle - \langle A \rangle \langle B \rangle$ . This result illustrates the idea that the entangled states carry information in the form of correlations between the local measurements [94].

## 5.4 Quantum Phase of Electric Dipole (E1) Photons

The problem of quantum phase was discussed in quantum optics for a long time (for review, see Refs. [95, 96, 97]). Among the results in the field, the two should be mentioned, first of all. One is the so-called Pegg-Barnett approach [98, 99] (for further references, see [96]). Their method is based on a contraction of the infinite-dimensional Hilbert space of photons  $\mathcal{H}$ . Viz, the quantum phase is first defined in an arbitrary  $s$ -dimensional subspace in  $\mathcal{H}$ . The formal limit  $s \rightarrow \infty$  is taken only after the averaging of the operators, describing the physical quantities, have been calculated. The weak spot of the approach is that any restriction of dimension of the Hilbert-Fock space of photons leads to an effective violation of the algebraic properties of the photon operators. This, in turn, can lead to an inadequate picture of quantum fluctuations.

Another approach has been proposed by Noh, Fougères, and Mandel [100, 101]. It is based on the *operational* definition of the quantum phase (in terms of what can be measured). The main result of the approach is that *there is no unique quantum phase variable, describing universally the measured phase properties of the light*. This very strong statement has obtained a totally convincing confirmation in a number of experiments.

The use of SWR permits us to define the quantum phase of photons, corresponding to the azimuthal phase of their AM [87, 102], in the whole Hilbert space without any contraction. The approach proposed in Ref. [87] complements, in a sense, the Noh-Fougères-Mandel approach. In fact, it defines the quantum phase in terms of what can be emitted by a source.

Let us use again the Jaynes-Cummings Hamiltonian (5.18) and the atomic angular momentum (5.20). The latter can be specified by the operators

$$J_+^{(a)} = \sqrt{2}(R_{+0} + R_{0-}), \quad J_-^{(a)} = (J_+^{(a)})^\dagger, \quad J_z^{(a)} = R_{++} - R_{--}, \quad (5.28)$$

forming a representation of the  $SU(2)$  algebra:

$$[J_+^{(a)}, J_-^{(a)}] = 2J_z^{(a)}, \quad [J_z^{(a)}, J_\pm^{(a)}] = \pm J_\pm^{(a)}. \quad (5.29)$$

Since the enveloping algebra of (5.28)-(5.29) contains the uniquely defined Casimir operator

$$(\vec{J}^{(a)})^2 = 2 \sum_{m=-1}^1 R_{mm} = 2 \times \mathbf{1},$$

where  $\mathbf{1}$  denotes the unit operator in the three-dimensional Hilbert space, describing the excited atomic state, a dual phase-dependent representation of (5.28) can be constructed through the use of method proposed by Vourdas [44]. Viz, the rising and lowering operators in (5.28) can be represented in the "polar" form

$$J_+^{(a)} = J_r^{(a)} E, \quad J_-^{(a)} = E^\dagger J_r^{(a)},$$

where  $J_r^{(a)}$  is the Hermitian "radial" operator and  $E$  is the unitary ( $EE^\dagger = \mathbf{1}$ ) "exponential of the phase" operator. It is easily seen that

$$E = R_{+0} + R_{0-} + e^{i\psi} R_{-+}, \quad (5.30)$$

where  $\psi$  denotes an arbitrary real reference phase. Using (5.30), one can define the cosine and sine of the atomic AM azimuthal phase operators

$$C^{(a)} = \frac{1}{2}(E + E^+), \quad S^{(a)} = \frac{1}{2i}(E - E^+), \quad (5.31)$$

such that

$$[C^{(a)}, S^{(a)}] = 0 \quad \text{and} \quad (C^{(a)})^2 + (S^{(a)})^2 = \mathbf{1}.$$

The phase states of the atomic AM are then defined to be the eigenstates of the operator (5.30)

$$E|\phi_m\rangle = e^{i\phi_m}|\phi_m\rangle,$$

which leads

$$|\phi_m\rangle = \frac{1}{\sqrt{3}} \sum_{m'=-1}^1 e^{-im'\phi_m} |j=1, m'\rangle, \quad \phi_m = \frac{\psi + 2m\pi}{3}, \quad (5.32)$$

where  $m$  acquires the values 0 and  $\pm 1$  as above. Through the use of the phase states (5.32), it is easy to define the following dual representation of the  $SU(2)$  algebra (5.28)-(5.29):

$$\mathcal{J}_{\pm}^{(a)} = \sum_m \sqrt{2 - m(m \pm 1)} |\phi_{m \pm 1}\rangle \langle \phi_m|, \quad \mathcal{J}_z^{(a)} = \sum_m m |\phi_m\rangle \langle \phi_m|. \quad (5.33)$$

It should be stressed that the  $SU(2)$  phase states can be constructed for an arbitrary number of two-level atoms. In particular, it can be shown that the  $SU(2)$  phase states form the set of maximum entangled  $2N$ -qubit states [6]

The representation of the  $SU(2)$  subalgebra in the Weyl-Heisenberg algebra of E1 photons (5.11) has the form

$$J_+^{(ph)} = \sqrt{2}(a_+^+ a_0 + a_0^+ a_-), \quad J_-^{(ph)} = (J_+^{(ph)})^+, \quad J_z^{(ph)} = \sum_m m a_m^+ a_m. \quad (5.34)$$

This expressions can be obtained directly from (5.22). The operators (5.34) complement the atomic operators (5.28) with respect to an integral of motion with the Hamiltonian (5.18). Unfortunately, there is no *isotype* representation of the  $SU(2)$  subalgebra in the Weyl-Heisenberg algebra [103]. In other words,

there is no uniquely defined Casimir operator in the enveloping algebra of (5.34). Therefore, Vourdas' [44] approach cannot be directly used here to describe the phase properties of AM of E1 photons.

At the same time, we again can use the conservation of AM in the process of radiation, which is independent of whether we use the standard form of AM operators or their dual representation. In particular, it is seen that [87]

$$[(E + \varepsilon), H] = 0,$$

where

$$\varepsilon = a_+^\dagger a_0 + a_0^\dagger a_- + e^{i\psi} a_-^\dagger a_+ \quad (5.35)$$

is the photon counterpart of the exponential of the phase operator (5.30). In contrast to (5.30), Eq. (5.35) does not determine a unitary operator. At the same time, (5.35) represents the *normal* operator

$$[\varepsilon, \varepsilon^\dagger] = 0,$$

commuting with the total number of photons

$$[\varepsilon, \sum_m a_m^\dagger a_m] = 0.$$

The quantum phase properties of E1 photons can now be described in terms of the dual representation of photon operators that has been introduced in Ref. [102]. Let us use the following Bogolubov-type [105] canonical transformation

$$a_m = \frac{1}{\sqrt{3}} \sum_{m'=-1}^1 e^{-im'\phi_m} \mathbf{a}_{m'}, \quad \mathbf{a}_m = \frac{1}{\sqrt{3}} \sum_{m'=-1}^1 e^{im'\phi_m} a_{m'}, \quad [\mathbf{a}_m, \mathbf{a}_{m'}^\dagger] = \delta_{mm'} \quad (5.36)$$

Here  $\phi_m$  represents the same phase angle as above. It is seen that the operator (5.35) takes the diagonal form in the representation (5.36):

$$\varepsilon_\phi = \sum_{m=-1}^1 e^{i\phi_m} \mathbf{a}_m^\dagger \mathbf{a}_m. \quad (5.37)$$

Let us note that the atomic operator (5.30) is also diagonal in the representation of phase states (5.32)

$$E_\phi = \sum_m e^{i\phi_m} |\phi_m\rangle \langle \phi_m|$$



and that

$$[(E_\phi + \varepsilon_\phi), H] = 0.$$

Thus, all one can conclude is that the operators  $\mathbf{a}_m$  and  $\mathbf{a}_m^+$  (5.36) provide a representation of E1 photon operators of annihilation and creation with *given quantum phase* that, by construction, is the azimuthal phase of AM of photons.

In particular, the annihilation operators in the phase representation (5.36) obey the stability condition

$$\forall m \quad \mathbf{a}_m |0\rangle = 0,$$

where  $|0\rangle$  is the vacuum state. Thus, the conjugated creation operator can be used to construct the Fock number states in the phase representation in usual way:

$$|\nu_m\rangle = \frac{1}{\sqrt{\nu_m!}} (\mathbf{a}_m^+)^{\nu_m} |0\rangle, \quad \mathbf{a}_m^+ \mathbf{a}_m |\nu_m\rangle = \nu_m |\nu_m\rangle, \quad \nu_m = 0, 1, \dots, \quad (5.38)$$

such that

$$\langle \nu_m | \nu_{m'} \rangle = \delta_{mm'}, \quad \bigotimes_{m=-1}^1 \sum_{\nu_m} |\nu_m\rangle \langle \nu_m| = \mathbf{1}. \quad (5.39)$$

Thus, the photon phase states  $|\nu_m\rangle$  form a complete orthonormal denumerable set of states of E1 photons, spanning the "phase" Hilbert-Fock space. This space is dual to the conventional space of states of E1 photons. It is seen that

$$\varepsilon_\phi |\nu_m\rangle = \nu_m e^{i\phi_m} |\nu_m\rangle.$$

Thus, (5.37) can be interpreted as the non-normalized exponential of the phase operator. In turn, the cosine and sine of the photon phase operators can be defined as follows

$$C_\phi^{(ph)} = K \sum_m \mathbf{a}_m^+ \mathbf{a}_m \cos \phi_m, \quad S_\phi^{(ph)} = K \sum_m \mathbf{a}_m^+ \mathbf{a}_m \sin \phi_m, \quad (5.40)$$

where the normalization coefficient  $K$  is defined by the condition

$$\langle (C_\phi^{(ph)})^2 + (S_\phi^{(ph)})^2 \rangle = 1 \quad (5.41)$$

for the averaging over an arbitrary state of the radiation field. Similar coefficient was used in the Noh-Fougères-Mandel operational approach as well [101].

The phase representation (5.36) can be used to describe the azimuthal phase of AM of E1 photons [87, 106, 107, 102, 97]. In particular, it is possible to show that the eigenvalues of the azimuthal quantum phase of AM of photons have a discrete spectrum, depending on the number of photons. All eigenvalues lie in the interval  $[0, 2\pi]$ . In the classical limit, provided by the high-intensity coherent state of radiation, the phase eigenvalues are distributed uniformly over the interval  $[0, 2\pi]$  as all one can expect in classical domain [102, 97].

The comparison with the Pegg-Barnett approach shows the qualitative coincidence of results for mean value of the cosine and sine operators. At the same time, there is a striking difference in the behavior of variance of quantum phase in the case of very few photons, corresponding to the quantum domain [106, 97].

## 5.5 Polarization of Multipole Photons

The polarization is usually defined to be the measure of transversal anisotropy of electromagnetic field with respect to the direction of propagation provided by the Poynting vector  $\vec{P}$  [84]. Quantum electrodynamics interprets the polarization as given spin state of photons [74]. In spite of the fact that spin is equal to 1 and hence has three states, the photons have only two polarizations because of the Poincaré invariance.

In PWR, direction of  $\vec{P}$  always coincides with  $\vec{k}/k$ . Thus, the polarization is a global property of photons in PWR. However, this is no longer a case for SWR, where  $(\vec{r} \times \vec{P})$  is not equal to zero, at least in a certain vicinity of the source.

As a matter of fact, E1 radiation obey the condition  $(\vec{r} \cdot \vec{B}) = 0$ , while the electric field  $\vec{E}$  is not orthogonal to the radial direction [8]. Therefore, if we discuss the radiation in the "laboratory frame" spanned by the basis (5.4) with the origin at the atom location, the three polarizations should be taken into

account [108, 109].

This fact can be illustrated in the following way. Within the relativistic picture, the field is described by the field-strength tensor

$$F_{\alpha\beta} = \partial_\alpha A_\beta - \partial_\beta A_\alpha = \begin{pmatrix} 0 & E_x & E_y & E_z \\ -E_x & 0 & -B_z & B_y \\ -E_y & B_z & 0 & -B_x \\ -E_z & -B_y & B_x & 0 \end{pmatrix}. \quad (5.42)$$

Since the anisotropy of the field can be specified by the lengths of the vectors and angles between the components, consider the following  $(4 \times 4)$  matrix

$$\mathcal{R} = F^+ F = \begin{pmatrix} (\vec{E}^+ \cdot \vec{E}) & \vec{P} \\ \vec{P}^+ & \mathcal{P} \end{pmatrix}.$$

Here  $F$  ( $F^+$ ) denotes the positive- (negative)-frequency part of (5.42),  $\vec{P}$ , apart from an unimportant factor, coincides with the positive-frequency part of the Poynting vector, and  $\mathcal{P}$  is the Hermitian  $(3 \times 3)$  matrix additive with respect to contributions coming from electric and magnetic fields

$$\mathcal{P} = \mathcal{P}_E + \mathcal{P}_B, \quad (5.43)$$

where

$$\mathcal{P}_{E\alpha\beta} = E_\alpha^+ E_\beta, \quad \alpha, \beta = x, y, z \quad (5.44)$$

and

$$\mathcal{P}_{B\alpha\beta} = \begin{cases} \vec{B}^+ \cdot \vec{B} - B_\alpha^+ B_\alpha & \text{at } \alpha = \beta \\ -B_\alpha^+ B_\beta & \text{otherwise} \end{cases}. \quad (5.45)$$

Thus, the matrix (5.43)-(5.45) specifies the magnitudes of the components and the angles between the components of the complex field strengths in the "laboratory frame" with the origin at the source location. We chose to interpret (5.43) as the general polarization matrix[104].

To justify this choice, consist first the case of plane waves propagating in the  $z$ -direction. Then, because of relations  $B_x = -E_y$  and  $B_y = E_x$ , both terms in

(5.43) are reduced to the same  $(2 \times 2)$  matrix of the form

$$\begin{pmatrix} E_x^+ E_x & E_x^+ E_y \\ E_y^+ E_x & E_y^+ E_y \end{pmatrix},$$

that is, to the conventional polarization matrix [84]. In the case of multipole radiation, the matrices (5.44) and (5.45) can also be reduced to the  $(2 \times 2)$  conventional polarization matrices by a local unitary transformation, rotating the  $z$ -axis in the direction of Poynting vector  $\vec{P}(\vec{r})$  at any point  $\vec{r}$ .

The diagonal terms in (5.44) give the radiation intensities of the components. The off-diagonal terms give the "phase information" described by the phase differences

$$\Delta_{\alpha\beta} = \arg E_\alpha - \arg E_\beta, \quad \Delta_{xy} + \Delta_{yz} + \Delta_{zx} = 0.$$

The polarization matrices (5.44) and (5.45) can also be expressed in the helicity basis (5.4) through the use of the unitary transformation

$$U \begin{pmatrix} E_x \\ E_y \\ E_z \end{pmatrix} = \begin{pmatrix} E_+ \\ E_0 \\ E_- \end{pmatrix}, \quad U = \frac{1}{\sqrt{2}} \begin{pmatrix} 1 & i & 0 \\ 0 & 0 & \sqrt{2} \\ -1 & i & 0 \end{pmatrix}$$

and similar transformation for  $\vec{B}$ . Then,  $U\mathcal{P}_E U^+$  coincides, to within the transposition of columns, with the polarization matrix with elements

$$\tilde{\mathcal{P}}_{\mu\mu'} = E_\mu^+ E_{\mu'}, \quad \mu, \mu' = 0, \pm 1, \quad (5.46)$$

have been introduced in [108].

Since  $\vec{E}(\vec{r}) \cdot \vec{B}(\vec{r})$  at any point  $\vec{r}$  and  $\vec{r} \cdot \vec{B} = 0$  for the electric-type radiation, the complete information about the phase differences is provided by the matrix (5.44) or by the equivalent matrix (5.46) in this case. In the case of magnetic-type radiation with  $\vec{r} \cdot \vec{E} = 0$ , the matrix (5.45) should be used instead of (5.44) [110].

Consider now the quantum E1 radiation. In this case, the field amplitudes should be changed by corresponding operators. Let us note that in addition

to (5.46) defined in terms of *normal product* of photon operators, we can also construct the anti-normal ordered polarization matrix

$$\tilde{\mathcal{P}}_{\mu\mu'}^{(an)} = E_{\mu'} E_{\mu}^+.$$

Then, the difference

$$\tilde{\mathcal{P}}_{\mu\mu'}^{(0)} \equiv \tilde{\mathcal{P}}_{\mu\mu'}^{(an)} - \tilde{\mathcal{P}}_{\mu\mu'} = [E_{\mu}, E_{\mu'}^+] \quad (5.47)$$

defines the elements of the *vacuum polarization matrix*, in other words, the zero-point oscillations (ZPO) of polarization [111]. It is easily seen that ZPO of polarizations depend on the distance from the source  $r$  and have a uniform angular distribution. Consider first the  $z$ -direction when  $\theta = 0$  and

$$Y_{j\pm 1, m-\mu}(0, \phi) = \sqrt{\frac{2(j \pm 1) + 1}{4\pi}} \delta_{m\mu}$$

for all  $\phi$ . Then, taking into account the definition of vector spherical harmonics (5.5), operator vector potential (5.10), and commutation relations (5.11), for the right-hand side of (5.47) we get

$$\tilde{\mathcal{P}}_{\mu\mu'}^{(0)}(r, 0, \phi) = \begin{cases} N_E^2 \left[ j_2(kr) \langle 12\mu 0 | 1\mu \rangle \sqrt{\frac{5}{4\pi}} - j_0(kr) \sqrt{\frac{1}{2\pi}} \right]^2 & \text{at } \mu = \mu' \\ 0 & \text{otherwise} \end{cases} \quad (5.48)$$

Because of the  $SU(2)$  invariance of the operator vector potential, proven in Sec. II, there is a local unitary transformation  $V(\vec{r})$ , transforming (5.47) into (5.48) at any point. For explicit form of  $V$  see Ref. [97]. Since  $\langle 1210 | 11 \rangle = \langle 12, -1, 0 | 1, -1 \rangle = 1/\sqrt{10}$  and  $\langle 1200 | 10 \rangle = -\sqrt{(2/5)}$ , the transversal (with respect to  $\vec{r}$ ) elements  $\tilde{\mathcal{P}}_{\pm\pm}^{(0)}$  in (5.48) have equal magnitude. In view of definition of spherical Bessel functions, it is seen that ZPO of polarization are strong enough in the near and intermediate zones, while vanish at  $r \rightarrow \infty$ .

Let us now apply the above unitary transformation to the components operator vector potential of E1 field  $V(\vec{r}) \vec{A}_{E1k\mu}(\vec{r})$  and calculate the commutator

$$[V(\vec{r}) \vec{A}_{E1k\mu}(\vec{r}), \vec{A}_{E1k\mu'}^+(\vec{r}) V^+(\vec{r})] = \delta_{\mu\mu'} \times \begin{cases} \tilde{\mathcal{P}}_{++}^{(0)}(r) & \text{at } \mu = \pm 1 \\ \tilde{\mathcal{P}}_{00}^{(0)}(r) & \text{at } \mu = 0 \end{cases}$$

It is seen that these relations coincide with (5.11) to within the distance-dependent factors, describing ZPO of polarization. In turn, the normalized operators

$$b_{k\mu}(\vec{r}) = \frac{V(\vec{r})\vec{A}_{E1k\mu}(\vec{r})}{\sqrt{\tilde{\mathcal{P}}_{\mu\mu}^{(0)}(r)}} \quad (5.49)$$

obey the commutation relations (5.11) at any point  $\vec{r}$  and hence form a local representation of the Weyl-Heisenberg algebra of E1 photons. Instead of the global index  $m$ , specifying AM, they depend on the coordinates  $\mu$ . In other words, they specify the field oscillations in the "laboratory frame" spanned by the helicity basis (5.4) and hence can be interpreted as the *local operators of E1 photons with given polarization* [111]. This means that the eigenstates of the number operators  $b_{\mu}^{\dagger}(\vec{r})b_{\mu}(\vec{r})$  give the number states of E1 photons with given polarization  $\mu$  at any point  $\vec{r}$ .

In fact, Eq. (5.49) represents a local Bogolubov-type canonical transformation from the photon operators with given  $m$  to the photon operators with given  $\mu$

$$b_{k\mu}(\vec{r}) = \frac{1}{\sqrt{\tilde{\mathcal{P}}_{\mu\mu}^{(0)}(r)}} \sum_m \sum_{\mu'} (-1)^{\mu'} V_{\mu\mu'}(\vec{r}) \mathcal{A}_{k m \mu'}(\vec{r}) a_m \equiv \sum_m \mathcal{B}_{m\mu}(\vec{r}) a_m, \quad (5.50)$$

where  $\mathcal{A}$  denotes the mode function. Since  $\det[\mathcal{B}] \neq 0$ , there is an inverse transformation, representing operators  $a_m$  in terms of  $b_{\mu}$ .

It is a straightforward matter to show that, in the representation of local operators (5.49)-(5.50), the polarization matrix (5.46), apart from an unimportant constant factor, takes the form

$$\tilde{\mathcal{P}}_{\mu\mu'}(\vec{r}) = b_{\mu}^{\dagger}(\vec{r})b_{\mu'}(\vec{r}). \quad (5.51)$$

Assume now that the two-level E1 transition have been discussed in previous sections emits a single photon in the state  $|1_m\rangle$ . Then the averaging of (5.51) over this state gives the polarization at any point  $\vec{r}$  described by the matrix with elements

$$\langle \tilde{\mathcal{P}}_{\mu\mu'}(\vec{r}) \rangle = \frac{\mathcal{B}_{m\mu}^*(\vec{r})\mathcal{B}_{m\mu'}(\vec{r})}{\tilde{\mathcal{P}}_{\mu\mu}^{(0)}(r)}. \quad (5.52)$$

Taking again into account that the properties of a multipole photon correspond to a spherical shell of radius  $r$ , we should integrate (5.52) over  $\sin\theta d\theta d\phi$  to get the polarization matrix of the photon at any distance  $r$  from the atom like we did in Sec. III for the spin carried by photon. In particular, it can be seen that the photons with any  $m$  have only two circular polarizations  $\mu = \pm 1$  in the wave zone [109] even in the "laboratory frame".

It should be emphasized that the polarization can also be described in terms of Stokes parameters that become the Stokes operators in quantum domain [112]. In the case of polarization of photons in SWR and in the "laboratory frame" defined by the basis (5.4), we have three independent directions of electric field oscillations. Since we have three degrees of freedom, the set of Hermitian Stokes operators is provided by the generators of the  $SU(3)$  subalgebra in the local Weyl-Heisenberg algebra of operators (5.49). In other words, the Stokes operators in "laboratory frame" coincide with (5.27) with the substitution of  $b_\mu(\vec{r})$  instead of  $a_m$  [97].

In this way, the quantum properties of polarization of E1 photons can be described, including the quantum fluctuations of polarization [109, 97].

## 5.6 Summary

We have reviewed some recent results concerning the quantum radiation by multipole transitions in atoms and molecules. It is shown that because of the radical difference of the dynamic symmetry group of the Hilbert spaces, the use of SWR leads to a more adequate picture of AM in quantum domain than PWR. In particular, SWR permits us to evaluate the quantum fluctuations of AM of photons. It is also shown that spin and OAM contribute equally into the total AM of photons in the wave zone, while spin prevail over OAM in the near and intermediate zones [114].

It is also shown that the cascade decay of E2 transition can lead to creation of E1 photon twins in the qutrit maximum entangled with respect to AM state.

This state correspond to the criterion of maximum entanglement of Refs. [6, 91] and manifests maximum correlation of local measurements. Let us stress that usually the qubit polarization entangled states of photons created by the cascade decay of two-level atom are considered in PWR (e.g., see [9]).

The use of SWR permits us to define the inherent quantum phase of multipole photons that is the azimuthal phase of AM. This definition develops the operational approach by Noh, Fougères and Mandel [100, 101]. The approach based on the polar decomposition of AM does not violate the algebraic properties of photon operators and leads to a qualitatively different picture of quantum fluctuations of phase from that obtained within the Pegg-Barnett approach [96, 98, 99].

It should be stressed that the approach based on the consideration of the  $SU(2)$  phase states has shown its efficiency in the problem of definition of maximum entangled N-qubit states [6] in the atomic entanglement has been proposed in Ref. [4, 113] and in quantum cryptography [44]. In particular, it can be used to specify the qubit multipartite states in three-level atoms [68]. It can also be applied to classification of maximum entangled states that can be obtained through the use of strong-driving-assisted processes in cavity QED.

Finally, the use of SWR permits us to describe the quantum properties of polarization at any distance from the source. Since the polarization is a local property of multipole radiation, the representation of the Weyl-Heisenberg algebra of photons with given polarization at any distance from the source can be constructed through the use of SWR. It should be stressed that usually the problem of photon localization is discussed in terms of wave functions (see [115] and references therein). At first sight, there is no principle contradiction between the approaches based on the use of operators and wave functions. A connection between the approaches deserves a more detailed investigation.



# Chapter 6

## Conclusions

Let us briefly summarize our results. We have proposed a new variational principle for definition of maximally entangled (ME) states which can be used as an operational definition i.e. what can be measured. Using this approach we have shown that well known ME states like EPR states can be derived from this principle. In addition to this, we have also shown that a single particle entangled state (a qutrit) exists. We have proposed some physical realizations of single particle entanglement.

Next, it is shown that the maximum entangled atomic states are represented by the  $SU(2)$  phase states of spin  $1/2$ . Moreover, the  $SU(2)$  phase states of the half-integer spin  $j$  form a certain class of maximum entangled atomic states in the system of  $2n$  two-level atoms interacting with  $n$  photons. In particular, the violation of classical realism is shown. The  $SU(2)$  phase states represent an important example of the atomic entangled states. First of all, they can be easily realized in the atomic systems in a cavity. The realization of a pure atomic entanglement in the  $2n + n$ -type atom + photon systems strongly depends on the choice of initial state. Viz, the entangled states can be reached in the process of steady-state evolution only if all  $2n$  atoms are initially in the de-excited states, while the cavity contains just  $n$  photons. This condition has an intuitively clear explanation: the excitations of different atoms have the same probability and therefore each photon in the  $2n + n$ -system is shared with a couple of atoms.

It is well known that producing maximally entangled states are not enough for physical applications like quantum coding or resources for quantum teleportation. They should be robust for certain environmental destructive effects. In Chapter 4, we have proposed a new Mini-max principle in order to stabilize the maximum entangled state. It is necessary to prepare the system  $S$  in a state, which obey the condition for maximally entangled state together with the condition of minimum (at least local minimum) of energy. This can be achieved by means of interaction of the system  $S$  with a certain dissipative environment. As an example we have considered two  $\Lambda$ -type atom in a cavity. Using the adiabatic elimination of the upper atomic levels we have shown that long standing entangled state is generated. Another advantage of using this proposed schema is the simple monitoring of entanglement via detection of Stokes photon.

In the last chapter, we have discussed the properties of multipole radiation generated by atomic transitions. Although plane and spherical wave representations are the same in classical picture, they are quite different in quantum domain because they describe different physical observables which cannot be measured at once such as linear and angular momentum. We have discussed angular momentum (AM) of a photon generated by a multipole transition from an atom using spherical wave representation. In particular, we examine AM entanglement of two photons emitted by a cascade decay of an electric quadrupole transition i.e. generation of two qutrit entangled state. In the last part of the chapter we have discussed spatial properties of polarization for multipole radiation.

# Bibliography

- [1] G. Raithel, C. Wagner, H. Walther, L. M. Narducci, and M. O. Scully, in *Advances in Atomic, Molecular and Optical Physics*, Ed. by P. Berman (Academic, New York, 1994).
- [2] H. Walther, in *Quantum Communication and Information Technologies*, Ed. by A. S. Shumovsky and V. I. Rupasov (Kluwer Academic, Dordrecht, 2003).
- [3] C. H. Bennett and P. W. Shor, *IEEE Trans. Inf. Theory*, **44**, 2724 (1998).
- [4] M.B. Plenio, S.F. Huelga, A. Beige, and P.L. Knight, *Phys. Rev. A* **59**, 2468 (1999).
- [5] A. Beige, S. Bose, D. Braun, S.F. Huelga, P.L. Knight, M.B. Plenio and V. Vedral, *J. Mod. Opt.* **47**,2583 (2000).
- [6] M.A. Can, A.A. Klyachko, and A.S. Shumovsky, *Phys. Rev. A* **66**, 022111 (2002).
- [7] Yanhua Shih, *Rep. Prog. Phys.* **66**,1009 (2003).
- [8] J.D. Jackson, *Classical Electrodynamics*. New York: Wiley.(1975).
- [9] L. Mandel, and E. Wolf. *Optical Coherence and Quantum Optics*, New York: Cambridge University Press.(1995).
- [10] W. Heitler, *The Quantum Theory of Radiation*, 3rd edition. London: Clarendon Press.(1954).

- [11] C. Cohen-Tannouji, J. Dupont-Roc, and G. Grinberg. *Atom-Photon Interaction*. New York: Wiley.(1992).
- [12] E. Schrödinger, *Naturwissenschaften*, **23**, 807; 823; 844 (1935).
- [13] A. Einstein, B. Podolsky, and N. Rosen, *Phys. Rev.* **47**, 777 (1935).
- [14] C. H. Bennett, G. Brassard, C. Crepeau, R. Jozsa, and W. Wootters, *Phys. Rev. Lett.* **70**, 1895 (1993).
- [15] D. Boschi, S. Branca, F. D. Martini, L. Hardy, and S. Popescu, *Phys. Rev. Lett.* **80**, 1121 (1998).
- [16] D. Bouwmeester, J. W. Pan, K. Mattle, M. Eibl, H. Weinfurter, and A. Zeilinger, *Nature*, **360**(6660), 575 (1997).
- [17] A. Furusawa, J. L. Sorensen, S. L. Braunstein, C. A. Fuchs, H. J. Kimble, and E. S. Polzik, *Science*, **282**, 706 (1998).
- [18] M. A. Nielsen, E. Knill, and R. Laflamme, *Nature*, **396**(6706), 52 (1998).
- [19] J. S. Bell, *Rev. Mod. Phys.* **38**, 447 (1966).
- [20] C.E. Shannon, *Bell Sys. Tech. Journal*,**27**, 379-423, 623-656 (1948).
- [21] A. Wehrl, *Rev. Mod. Phys.* **50**, 221 (1978).
- [22] M. Ohya and D. Petz, *Quantum Entropy and Its Use*, Springer-Verlag, Berlin (1993).
- [23] D.P. DiVincenzo, J. Smolin and W.K. Wootters, *Phys. Rev. A* **54**, 3824 (1996).
- [24] S. Hill and W.K. Wootters, *Phys. Rev. Lett.* **78**, 5022 (1997).
- [25] W.K. Wootters, *Phys. Rev. Lett.* **80**, 2245 (1998).
- [26] V. Coffman, J. Kundu, and W.K. Wootters, *Phys. Rev. A* **61**, 052306 (2000).
- [27] D.M. Greenberger, M. Horne, A. Simony, and A. Zeilinger, *Am. J. Phys.* **58**, 1131 (1990).

- [28] N.D. Mermin, Phys. Rev. Lett. **65**, 1838 (1990).
- [29] A.V. Belinskii and D.N. Klyshko, Phys. Usp. **36**, 460 (1993).
- [30] R. Horodecki, P. Horodecki, and M. Horodecki M., Phys. Lett. A **200**, 340 (1995).
- [31] A. Peres, Found. Phys. **29**, 589 (1999).
- [32] R.F. Werner and M.M. Wolf, Phys. Rev. A **64**, 010102(R) (2001).
- [33] D.M. Greenberger, M. Horne, and A. Zeilinger, in *Bell's Theorem, Quantum Theory, and Conceptions of the Universe* editor M. Kafatos (Kluwer, Dordrecht, 1989).
- [34] Č. Brukner, M. Žukovski, and A. Zeilinger, *The Essence of Entanglement*, arXiv:quant-ph/0106119v1.
- [35] A.A. Klyachko and A.S. Shumovsky, J. Opt. B **6**, S29 (2004); Laser Phys. **14**, 134 (2004).
- [36] W. Dür, G. Vidal, and J.I. Cirac, Phys. Rev. A **62**, 062314 (2000); F. Verstraete, J. Dehaene, B. De Moor, and H. Verschelde, Phys. Rev. A **65**, 052112 (2002).
- [37] A. Peres and D.R. Terno, Int. J. Quant. Info. **1**, 225 (2003).
- [38] A.A. Klyachko, E-print quant-ph/0206012.
- [39] A.A. Klyachko and A.S. Shumovsky, J. Opt. B **5**, S322 (2003).
- [40] E.P. Wigner, Z. Physik **131**, 101 (1952); E.P. Wigner and M.M. Yanase, Proc. Nat. Acad. Sci. USA **19**, 910 (1963).
- [41] M.Ali Can, Alexander Klyachko and Alexander Shumovsky ,*submitted to Journal of Optics B*.
- [42] J.F. Clauser, M.A. Horne, A. Shimoni, and R.A. Holt, Phys. Rev. Lett. **23**, 880 (1969).
- [43] M.B. Plenio and V. Verdal, Contemp. Phys. **39**, 431 (1998).

- [44] A. Vourdas, Phys. Rev. A **41**, 1653 (1990).
- [45] A.S. Shumovsky and Ö.E. Müstecaplıoğlu, J. Mod. Optics, **45**, 619 (1998).
- [46] A.S. Shumovsky, J. Phys. A **32**, 6589 (1999).
- [47] A.S. Shumovsky, in *Modern Nonlinear Optics, Part I, Second Edition, Advances in Chemical Physics*, Vol. 119. Edited by M.W. Evans. Series Editors I. Prigogine and S.A. Rice (Wiley New York, 2001).
- [48] M. Horodecki, P. Horodecki, and R. Horodecki, Phys. Rev. Lett. **80**, 5239 (1998).
- [49] M. Weidinger, B.T.H. Varcoe, R. Heerland, and H. Walther Phys. Rev. Lett. **82** 3795 (1999); S. Haroche, AIP Conf. Proc. **464**, 45 (1999).
- [50] G. Rempe, Ann Phys. (Leipzig) **9** 843 (2000).
- [51] M.A. Can, Ö. Çakır, A.C. Günhan, A.A. Klyachko, N.K. Pak, A.S. Shumovsky, Laser Physics, in press.
- [52] E. Hagley, X. Maitre, G. Nogules, C. Wunderlich, M. Brune, J.M. Raymond and S. Haroshe, Phys. Rev. Lett. **79**, 1 (1997).
- [53] A. Furusawa, J.L. Sørensen, S.L. Braunstein, C.A. Fuchs, H.J. Kimble and E.S. Polzik, Science, **282**, 706 (1998).
- [54] Q.A. Turchette, C.S. Wood, B.E. King, C.J. Myatt, D. Liebfried, W.M. Itano, C. Monroe and D.J. Wineland, Phys. Rev. Lett. **81**, 3631 (1998).
- [55] B. Bederson and H. Walther, *Advances In Atomic, Molecular, and Optical Physics*, Vol. 42, (New York: Academic Press) (2000).
- [56] G. Rempe, Ann. Phys., Leipzig, **9**, 843 (2000).
- [57] J.M. Raymond, M. Brune and S. Haroche, Rev. Mod. Phys. **73**, 565 (2001).
- [58] B. Julsgaard, A. Kozekhin and E. Polzik, Nature, **413**, 400 (2001).
- [59] E. Solano, G.S. Agarwal and H. Walther *e-print quant-ph/0202071* (2002).

- [60] E.U. Condon and G.H. Shortley, *The Theory of Atomic Spectra* (New York: Cambridge University Press, 1987).
- [61] C.E. Moore, *Atomic Energy Levels* (Washington DC: US National Bureau of Standards, 1971).
- [62] C.C. Gerry and J.H. Eberly, Phys. Rev. A **42**, 6805 (1990).
- [63] N.N. Bogolubov Jr, F. Le Kien, and A.S. Shumovsky, Europhys. Lett. **4**, 281 (1987); C.K. Law and J.H. Eberly, Phys. Rev. A, **47**, 3195 (1993); R.R. Puri, C.K. Law, and J.H. Eberly, Phys. Rev. A **50**, 4212 (1994).
- [64] C.W. Gardiner and P. Zoller, *Quantum Noise* (Springer, Berlin, 2000).
- [65] S. Osnaghi, P. Bertet, A. Auffeves, P. Maioli, M. Brune, J.M. Raymond, and S. Haroche, Phys. Rev. Lett. **87**, 037902 (2001).
- [66] M. Hennrich, T. Legero, K. Khun, and G. Rempe, Phys. Rev. Lett. **85**, 4872 (2000).
- [67] A.S. Shumovsky and Tran Kuang, in *Interaction of Electromagnetic Field with Condensed Matter*, edited by N.N. Bogolubov, A.S. Shumovsky, and V.I. Yukalov (World Scientific, Singapore, 1990).
- [68] M.A.Can, A.A.Klyachko, and A.S.Shumovsky, Applied Physics Letters, **81**, 5072 (2002).
- [69] M.A.Can, Ö.Çakır, A.A.Klyachko, and A.S.Shumovsky, Physical Review A, **68**, 022305 (2003).
- [70] Ö.Çakır, M.A.Can, A.A.Klyachko, and A.S.Shumovsky, Laser Physics, **14**, 1-5 (2004).
- [71] M.A.Can, Ö.Çakır, A.A.Klyachko, and A.S.Shumovsky, Journal of Optics B, **6**, S13-S17 (2004).
- [72] M.A.Can, O.Soykal, and A.S.Shumovsky, Chapter in Quantum Communication and Information Technologies, Kluwer Academic, Dordrecht, 2003.

- [73] H. Bateman, *The Mathematical Analysis of Electric and Optical Wave-Motion*. New York: Dover.(1955).
- [74] V.B. Berestetskii, E.M. Lifshitz, and L.P. Pitaevskii. *Quantum Electrodynamics*. Oxford: Pergamon Press.(1982).
- [75] E.P. Wigner, *Group theory and its application to the quantum mechanics of atomic spectra*. New York: Academic Press.(1959).
- [76] B. Bederson, and H. Walther. *Advances in Atomic, Molecular, and Optical Physics*, Vol. 42. New York: Academic Press.(2000).
- [77] J.M. Raymond,, M. Brune, and S. Haroche. *Rev. Mod. Phys.* **73**, 565.(2001).
- [78] H.H. Arnavut, and G.A. Barbosa. *Phys. Rev. Lett.* **85**, 286.(2000).
- [79] A. Mair, A. Vazari, G. Weihs, and A. Zeilinger. *Nature* **412**, 313.(2001).
- [80] M.J. Padgett, S.M. Barnett, S. Franke-Arnold, and J. Courtial. *Phys. Rev. Lett.* **88**, 257901.(2002).
- [81] A. Vazari, G. Weihs, and A. Zeilinger. *Phys. Rev. Lett.* **89**, 240401.(2002).
- [82] A. Muthukrishnan, and C.R. Stroud. *J. Opt. B* **4**, S73. (2002).
- [83] A.S. Davydov, *Quantum Mechanics* Oxford: Pergamon Press.(1976).
- [84] M. Born, and E. Wolf. *Principles of Optics* Oxford: Pergamon Press.(1970).
- [85] W.J. Thompson, *Angular Momentum* New York: Wiley.(1994).
- [86] S.J. Van Enk, and G. Nienhuis. *J. Mod. Opt.* **41**, 963.(1994).
- [87] A.S. Shumovsky, *Opt. Commun.* **136**, 219.(1997).
- [88] R. Acharya, and E.C.G. Sudarshan. *J. Math. Phys.* **1**, 532.(1960).
- [89] B. Davies, *Quantum Theory of Open Systems* New York: Academic Press.(1972).
- [90] C.W. Gardiner, and P. Zoller. *Quantum Noise* Berlin: Springer.(2000).



- [91] A.A. Klyachko, and A.S. Shumovsky., J. Opt. B **5** (2003)(in print); preprint quant-ph/0302008.
- [92] A.V. Burlakov, M.V. Chekhova, O.A. Karabutova, D.N. Klyshko, and S.P. Kulik. Phys. Rev. A **60**, R4209.(1999).
- [93] H. Bechmann-Pasquinucci, and A. Peres, Phys. Rev. Lett. **85**, 3313.(2000).
- [94] Č. Brukner, M. Żulowski, and A. Zeilinger. E-print quant-ph/0106119.(2001).
- [95] R. Lynch, Phys. Rep. **256**, 367.(1995).
- [96] R. Tanaś, A. Miranowitz, and T. Gantsog. Prog. Opt. **35**, 1.(1996).
- [97] A.S. Shumovsky, In *Modern Nonlinear Optics*, Pat 1, *Advances in Chemical Physics*, Vol. **119**, edited by M.W. Evans, Series editors I. Prigogine and S.A. Rice, New York: Wiley. (2001).
- [98] D.T. Pegg, and S.M. Barnett. Europhys. Lett. **6**, 483.(1988).
- [99] D.T. Pegg, and S.M. Barnett. J. Mod. Opt. **44**, 225.(1997).
- [100] J.W. Noh, A. Fougères, and L. Mandel. Phys. Rev. Lett. **67**, 1426.(1991).
- [101] J.W. Noh, A. Fougères, and L. Mandel. Phys. Rev. A **45**, 242.(1992).
- [102] A.S. Shumovsky, J. Phys. A **32**, 6589. (1999).
- [103] J.-P. Serre, *Linear Representations of Finite Groups* New York: Springer.(1977).
- [104] Muhammet Ali Can and Alexander S. Shumovsky, quant-ph/0105067.
- [105] N.N. Bogolubov, A.M. Kurbatov, and A.S. Shumovsky (Eds.). *N.N. Bogolubov Selected Works, Part II* New York: Gordon and Breach.(1991).
- [106] A.S. Shumovsky, and Ö. Müstecaplıođlu. Opt. Commun. **146**, 124.(1998).
- [107] A.S. Shumovsky, and Ö. Müstecaplıođlu. In *Causality and Locality in Modern Physics*, edited by G. Hunter, S. Jeffers, and J.-P. Vigiier, Dordrecht: Kluwer.(1998).

- [108] A.S. Shumovsky, and Ö. Müstecaphoğlu. *Phys. Rev. Lett.* **80**, 1202.(1998).
- [109] M.A. Can, and A.S. Shumovsky. *J. Mod. Opt.* **49**, 1423. (2002).
- [110] E. Wolf, *Nuovo Cimento* **12**, 884. (1954).
- [111] A.A. Klyachko, and A.S. Shumovsky. *Laser Phys.* **11**, 57.(2001).
- [112] J.M. Jauch, and F. Rohrlich. *The Theory of Photons and Electrons* Reading MA: Addison-Wesley.(1959).
- [113] A. Beige, W.J. Munro, and P.L. Knight. *Phys. Rev. A* **62**, 052102.(2000).
- [114] M.A.Can, Ö.Çakır, A.Horzela, E.Kapuscik A.A.Klyachko, and A.S.Shumovsky, *Laser Physics*, **14**, 1180-1184 (2004).
- [115] K.W. Can, C.K. Law, and J.H. Eberly. *Phys. Rev. Lett.* **88**, 100402. (2002).